

uría



Saleros y Azucareras





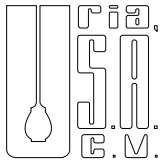

artículos de acero inoxidable
stainless steel products

clave
item no. **101 & 102**

101 pimentero "moderno" 102 salero "moderno"

Sin lugar a dudas, nuestro salero y pimentero más exitosos. Los preferidos por su calidad, capacidad y durabilidad.

El acero inoxidable con vidrio es la combinación por excelencia probada internacionalmente.

Su diseño los hace prácticamente irrompibles y de poco relleno dada su capacidad.

Convenientemente empacados en caja de 6 docenas.

101 "modern" pepper shaker 102 "modern" salt shaker

Our most successful salt and pepper shakers. Preferred for its quality, capacity and durability. Stainless steel with glass is the combination for worldwide excellence.

Its design makes them almost unbreakable and of low refilling.

Conveniently packed in 6 dozens.

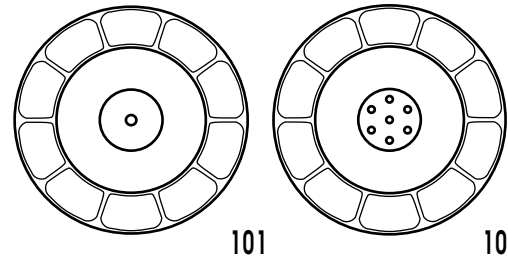
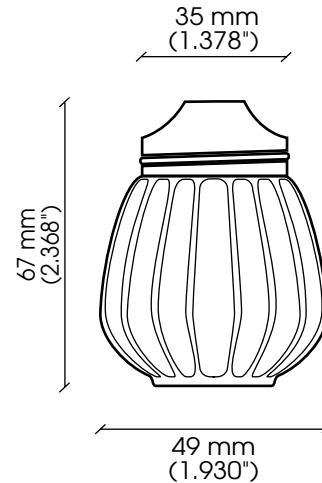

clave	tapa	recipiente	capacidad (ml.)	peso (kg.)	empaque (caja de cartón)
101	acero inoxidable	vidrio	50	.076	72 pzas. 5.90 kg. 300x300x165 mm.

item no.	top	container	capacity (fl.oz.)	weight (lbs.)	packaging (cardboard box)
101	stainless steel	glass	1.7	.17	72 pcs. 13.00 lbs. 11.8x11.8x6.5 in

NOTA: Uría se reserva el derecho de hacer cambios en la fabricación de sus artículos sin previo aviso. Asimismo en precios y disponibilidad.

NOTE: Uría reserves the right to make changes in the manufacturing of its products without advanced notice. Prices and availability subject to change.



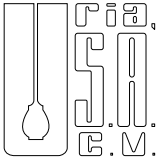

artículos de acero inoxidable
stainless steel products

clave
item no. **103**

103 salero "europeo"

La figura clásica de este salero lo hace perfecto para la mesa con este tipo de decoración.

Simplemente, calidad y economía en el mismo artículo.

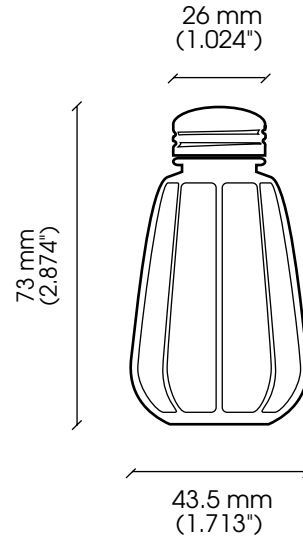

103 "european" salt shaker

The classic shape of this salt shaker makes it perfect for this type of table decoration.

...quality and economy in the same product.

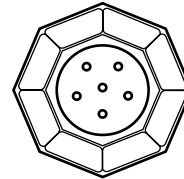

clave	tapa	recipiente	capacidad (ml.)	peso (kg.)	empaque (caja de cartón)
103	acero inoxidable	vidrio	40	.062	100 pzas. 6.50 kg. 300x300x165 mm.

item no.	top	container	capacity (fl.oz.)	weight (lbs.)	packaging (cardboard box)
103	stainless steel	glass	1.3	.14	100 pcs. 14.33 lbs. 11.8x11.8x6.5 in

NOTA: Uría se reserva el derecho de hacer cambios en la fabricación de sus artículos sin previo aviso. Asimismo en precios y disponibilidad.

NOTE: Uría reserves the right to make changes in the manufacturing of its products without advanced notice. Prices and availability subject to change.

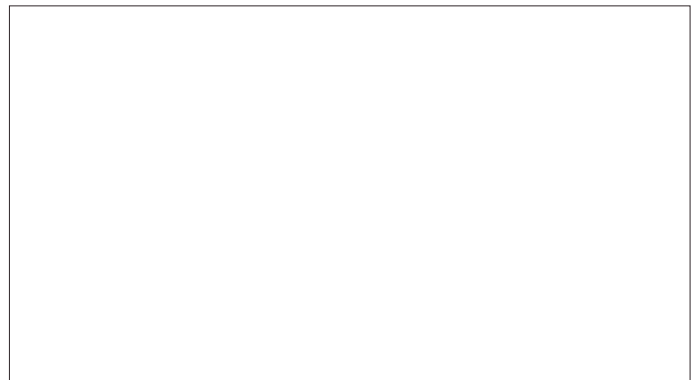



104 salero "de lujo"
 104 BIS pimentero "de lujo"
 114 azucarera "de lujo"

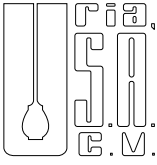

A la vista de sus clientes, usted necesita accesorios que sean a la vez elegantes y durables. Este juego de salero, pimentero y azucarera de vidrio pesado, se apega perfectamente a tal definición.

La creatividad de nuestros clientes los ha llevado a usar al pimentero como palillero y dada su transparencia y capacidad, usan estos artículos con diferentes condimentos como chile piquín, canela, orégano, etc.

¡ ES UN JUEGO INCREÍBLEMENTE VERSÁTIL !

104 "de luxe" salt shaker
 104 BIS "de luxe" pepper shaker
 114 "de luxe" sugar pourer

Being at the view of your customers, you need accessories to be as elegant as they are durable. This set of salt and pepper shakers and sugar pourer of heavy glass, matches this definition perfectly.

The creativity of our customers has led them to use the pepper shakers as a toothpick dispenser and due to its transparency and capacity, they use these products with different condiments such as red hot chili powder, cinnamon, oregano, etc.

AN INCREDIBLY VERSATILE SET !

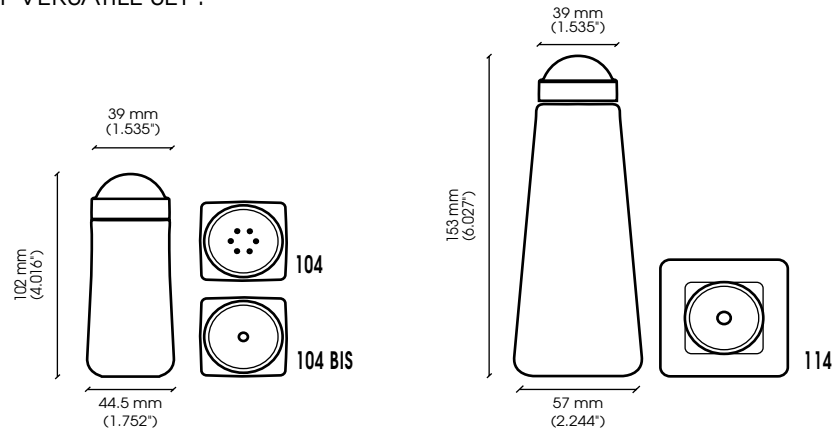

clave	tapa	recipiente	capacidad (ml.)	peso (kg.)	empaque (caja de cartón)
104	acero inoxidable	vidrio	60	.176	50 pzas.
104 BIS					9.00 kg.
114			230x230x225 mm.		
			151	.331	25 pcs.
					8.60 kg.
					300x300x165 mm.
item no.	top	container	capacity (fl.oz.)	weight (lbs.)	packaging (cardboard box)
104	stainless steel	glass	2.0	.39	50 pcs.
104 BIS					19.84 lbs.
114			9x9x8.9 in.		
			5.1	.73	25 pcs.
					18.96 lbs.
					11.8x11.8x6.5 in

NOTA: Uría se reserva el derecho de hacer cambios en la fabricación de sus artículos sin previo aviso. Asimismo en precios y disponibilidad.

NOTE: Uría reserves the right to make changes in the manufacturing of its products without advanced notice. Prices and availability subject to change.

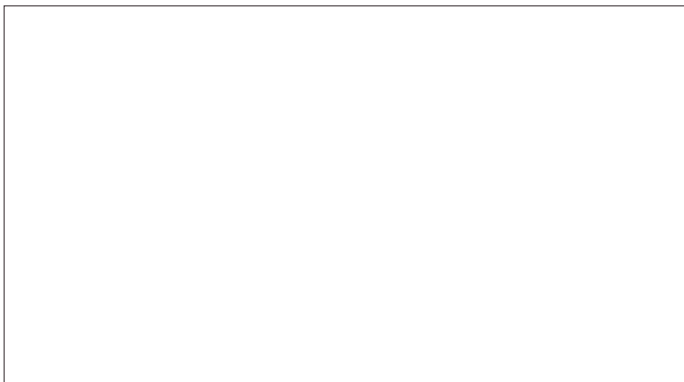

artículos de acero inoxidable
 stainless steel products
 clave item no.
 104, 104 BIS & 114



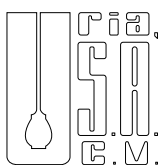

104 N salero "de lujo negro"
 104 NBIS pimentero "de lujo negro"
 114 N azucarera "de lujo negra"

Ponga un toque de sofisticación a su mesa con este increíble juego negro. Especialmente diseñado para decoraciones modernistas. Distíngase; sálgase de lo común y tradicional.

¡ ELEGANTE ! ¡ ULTRAMODERNO ! ¡ HIGH TECH !

104 N "black de luxe" salt shaker
 104 NBIS "black de luxe" pepper shaker
 114 N "black de luxe" sugar pourer

Add a touch of sophistication to your table with this incredible black set. Specially designed for modern style atmospheres. Distinguish yourself; leave what is common and traditional behind.

ELEGANT ! ULTRAMODERN ! HIGH TECH !

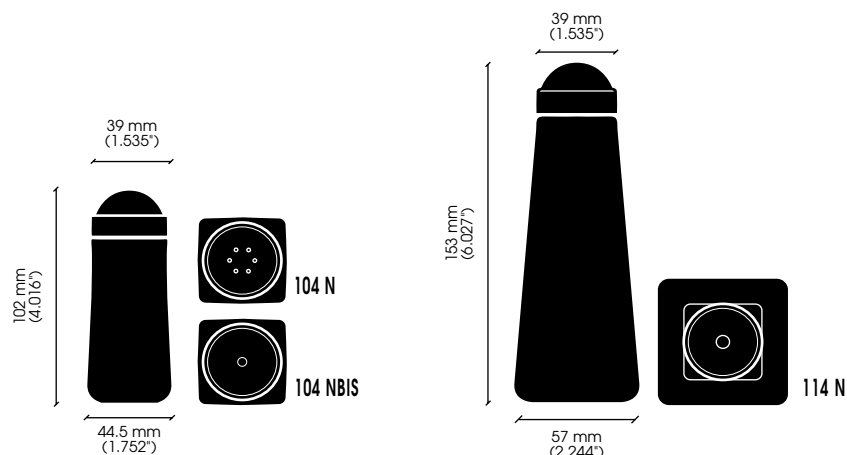

clave	tapa	recipiente	capacidad (ml.)	peso (kg.)	empaque (caja de cartón)
104 N 104 NBIS	acero inoxidable	vidrio	66	.163	50 pzas. 8.40 kg. 230x230x225 mm.
114 N			166	.285	25 pcs. 7.50 kg. 300x300x165 mm.

item no.	top	container	capacity (fl.oz.)	weight (lbs.)	packaging (cardboard box)
104 N 104 NBIS	stainless steel	glass	2.2	.36	50 pcs. 18.52 lbs. 9x9x8.9 in.
114 N			5.6	.63	25 pcs. 16.53 lbs. 11.8x11.8x6.5 in.

NOTA: Uría se reserva el derecho de hacer cambios en la fabricación de sus artículos sin previo aviso. Asimismo en precios y disponibilidad.

NOTE: Uría reserves the right to make changes in the manufacturing of its products without advanced notice. Prices and availability subject to change.

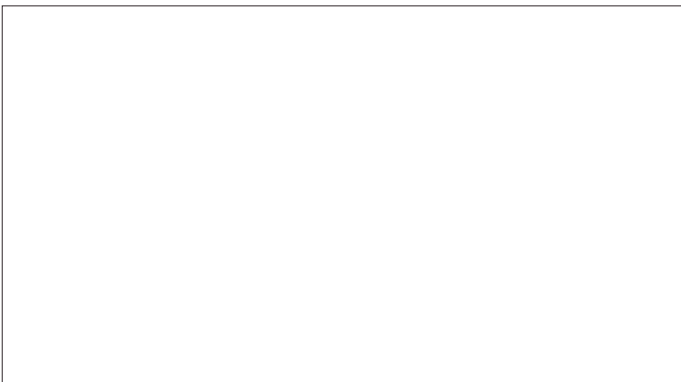

clave item no. 104 N, 104 NBIS & 114 N artículos de acero inoxidable stainless steel products

USA
C.V.



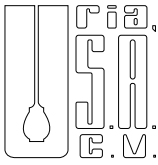

clave 104 D, 104 DBIS & 114 D
 item no. artículos de acero inoxidable
 stainless steel products

- 104 D salero "de lujo negro" tapa a.i.
- 104 DBIS pimentero "de lujo negro" tapa a.i.
- 114 D azucarera "de lujo negra" tapa a.i.

Combine este fino juego con otros accesorios para crear la atmósfera que desea. Su competencia se quedará asombrada.

- 104 D "black de luxe" salt shaker s.s. top
- 104 DBIS "black de luxe" pepper shaker s.s. top
- 114 D "black de luxe" sugar pourer s.s. top

Combine this fine set with other accessories to create just the look you want. Your competition will be astonished.

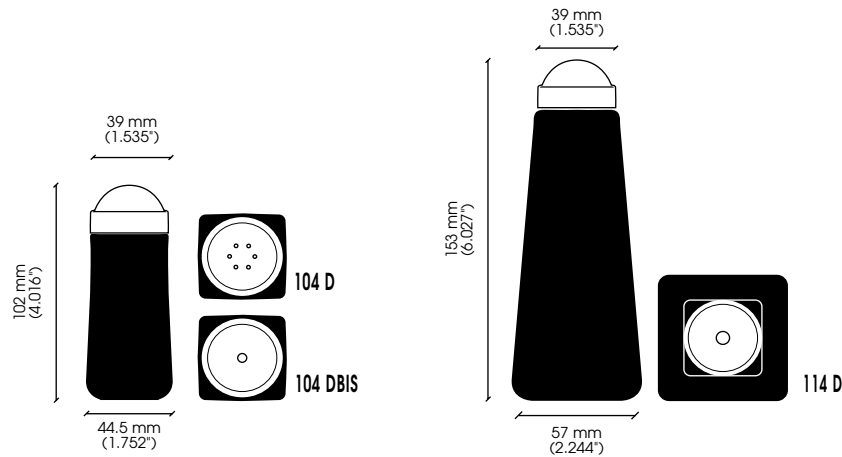

clave	tapa	recipiente	capacidad (ml.)	peso (kg.)	empaque (caja de cartón)
104 D 104 DBIS	acero inoxidable	vidrio	66	.163	50 pzas. 8.40 kg. 230x230x225 mm.
114 D			166	.285	25 pcs. 7.50 kg. 300x300x165 mm.

item no.	top	container	capacity (fl.oz.)	weight (lbs.)	packaging (cardboard box)
104 D 104 DBIS	stainless steel	glass	2.2	.36	50 pcs. 18.52 lbs. 9x9x8.9 in.
114 D			5.6	.63	25 pcs. 16.53 lbs. 11.8x11.8x6.5 in

NOTA: Uría se reserva el derecho de hacer cambios en la fabricación de sus artículos sin previo aviso. Asimismo en precios y disponibilidad.

NOTE: Uría reserves the right to make changes in the manufacturing of its products without advanced notice. Prices and availability subject to change.

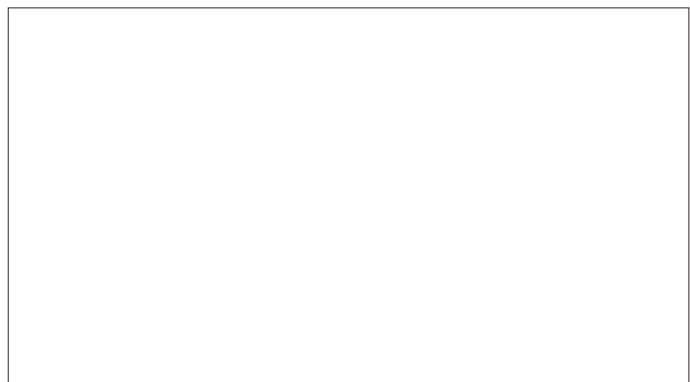



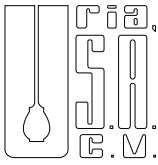

artículos de acero inoxidable
stainless steel products

clave item no. 106, 106 BIS & 116

- 106 salero "americano"
- 106 BIS pimentero "americano"
- 116 azucarera "americano"

Para decoraciones tradicionales y para cualquier arreglo de mesa.

La azucarera tiene una pequeña tapa en su orificio de servicio, para impedir la entrada de objetos extraños.

- 106 "american" salt shaker s.s. top
- 106 BIS "american" pepper shaker s.s. top
- 116 "american" sugar pourer s.s. top

For traditional decorations and any type of table presentation.

The sugar pourer has a small lid at the opening to obstruct the entrance of unwanted particles.

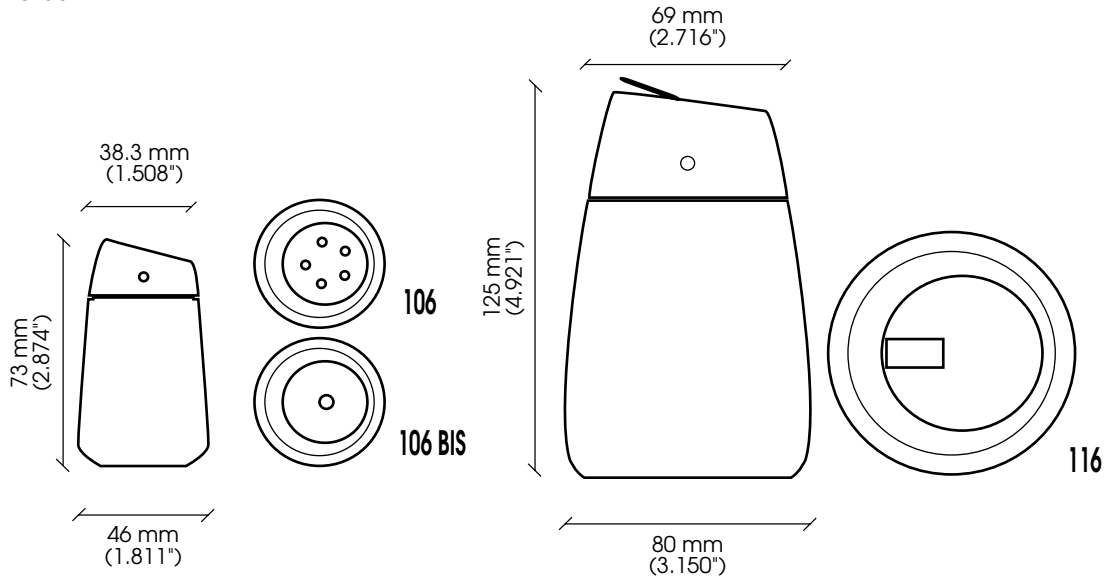

clave	tapa	recipiente	capacidad (ml.)	peso (kg.)	empaque (caja de cartón)
106 106 BIS	acero inoxidable	vidrio	45	.093	75 pzas. 7.20 kg. 230x230x225 mm.
116			275	.320	24 pcs. 8.40 kg. 260x400x250 mm.

item no.	top	container	capacity (fl.oz.)	weight (lbs.)	packaging (cardboard box)
106 106 BIS	stainless steel	glass	1.5	.20	75 pcs. 15.87 lbs. 9x9x8.9 in.
116			9.3	.71	24 pcs. 18.52 lbs. 10.2x15.7x9.8 in.

NOTA: Uría se reserva el derecho de hacer cambios en la fabricación de sus artículos sin previo aviso. Asimismo en precios y disponibilidad.

NOTE: Uría reserves the right to make changes in the manufacturing of its products without advanced notice. Prices and availability subject to change.



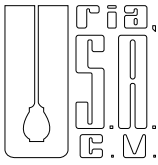

artículos de acero inoxidable
stainless steel products

clave 107 & 107 BIS,
item no. 107 S & 107 SBIS

- 107 salero "tequila"
- 107 BIS pimentero "tequila"
- 107 S salero "tequila satinado"
- 107 SBIS pimentero "tequila satinado"

Dé un toque especial a su local con el juego transparente o el satinado. Estos artículos fueron inspirados por el vaso para tequila "caballito".

El original sello entre tapa y frasco ha hecho que los cantineros lo utilicen para licores que se sirven en poca cantidad, como el amargo de angostura.

- 107 "tequila" salt shaker
- 107 BIS "tequila" pepper shaker
- 107 S "tequila frosted" salt shaker
- 107 SBIS "tequila frosted" pepper shaker

Personalize your establishment with either the clear or frosted set. They were inspired by the glass called "caballito" in which tequila is served.

The unique seal between the top and the container has made bartenders use them for liquors that are used in small quantities.

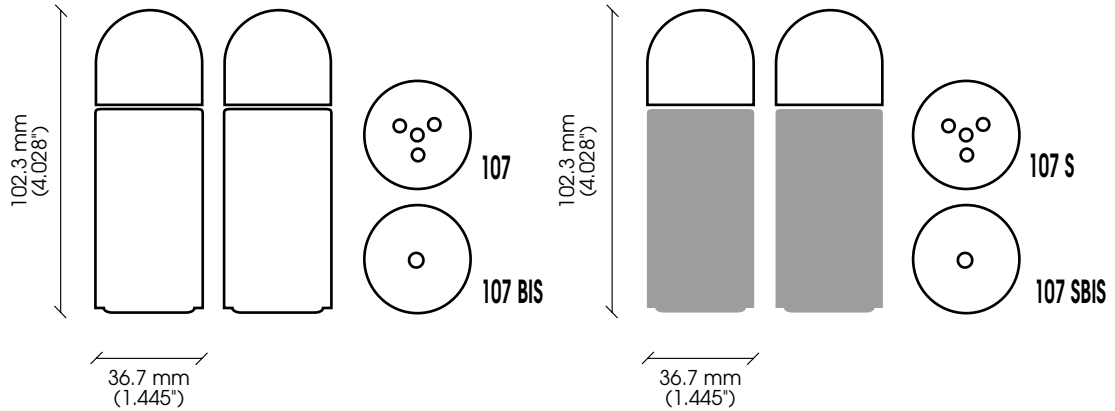

clave	tapa	recipiente	capacidad (ml.)	peso (kg.)	empaque (caja de cartón)
107 107 BIS	acero inoxidable	vidrio	40	.111	72 pzas. 8.30 kg. 230x230x225 mm.
107 S 107 SBIS		vidrio satinado			
item no.	top	container	capacity (fl.oz.)	weight (lbs.)	packaging (cardboard box)
107 107 BIS	stainless steel	glass	1.3	.24	72 pcs. 18.30 lbs. 9x9x8.9 in.
107 S 107 SBIS		frosted glass			

NOTA: Uría se reserva el derecho de hacer cambios en la fabricación de sus artículos sin previo aviso. Asimismo en precios y disponibilidad.

NOTE: Uría reserves the right to make changes in the manufacturing of its products without advanced notice. Prices and availability subject to change.



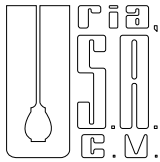

artículos de acero inoxidable
stainless steel products

clave
item no. **110**

110 azucarera "uría"

Resalte su mesa con la azucarera que por su diseño y construcción le gana a cualquier competencia. De gran capacidad, durabilidad y seguridad, ya que no tiene partes filosas. Una tapita cubre el orificio de servicio por higiene.

110 "uria" sugar pourer

Enhance your table with the sugar pourer that due to its design and construction beats any competition. With great capacity, durability and safety; there are no sharp edges. A small lid covers the pouring hole for hygiene.

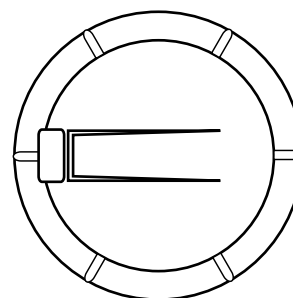
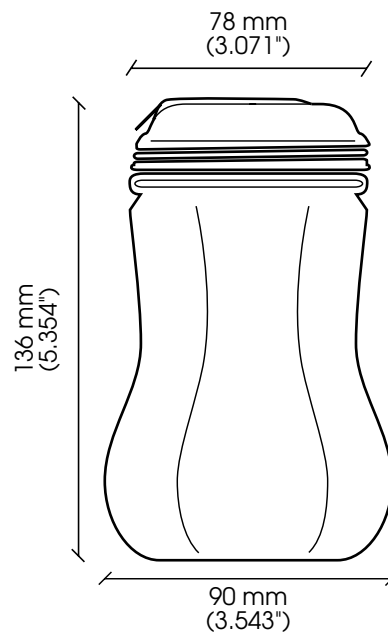

clave	tapa	recipiente	capacidad (ml.)	peso (kg.)	empaque (caja de cartón)
110	acero inoxidable	vidrio	355	.386	30 pzas. 12.40 kg. 310x440x290 mm.

item no.	top	container	capacity (fl.oz.)	weight (lbs.)	packaging (cardboard box)
110	stainless steel	glass	12	.85	30 pcs. 27.34 lbs. 12.27x17.3x11.4 in

NOTA: Uría se reserva el derecho de hacer cambios en la fabricación de sus artículos sin previo aviso. Asimismo en precios y disponibilidad.

NOTE: Uría reserves the right to make changes in the manufacturing of its products without advanced notice. Prices and availability subject to change.



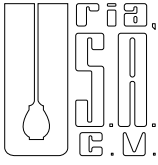

artículos de acero inoxidable
stainless steel products

clave
item no. **111**

111 especiera "uría"

Especiera de gran capacidad para contener cualquier tipo de condimento, queso parmesano, sal granulada, etc. Muy utilizada en la cocina del hogar, restaurants y en pizzerías.

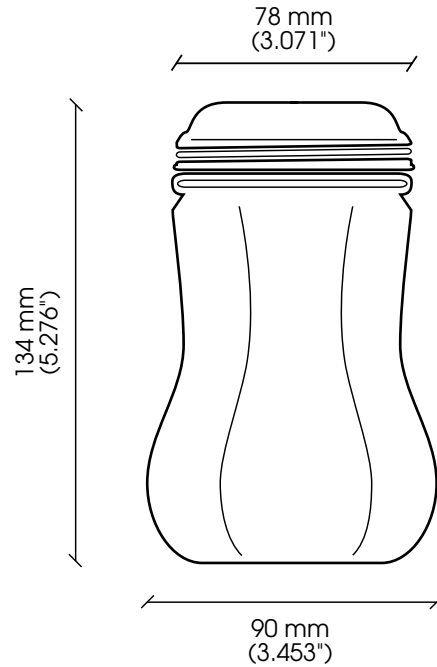

111 "uria" condiment shaker

Condiment shaker with great capacity to contain any spice, parmesan cheese, granulated salt, etc. Widely used at home, restaurant kitchens and pizza places.

clave	tapa	recipiente	capacidad (ml.)	peso (kg.)	empaque (caja de cartón)
111	acero inoxidable	vidrio	355	.386	12 pzas. 5.00 kg. 300x300x165 mm.

item no.	top	container	capacity (fl.oz.)	weight (lbs.)	packaging (cardboard box)
111	stainless steel	glass	12	.85	12 pcs. 11.02 lbs. 11.8x11.8x6.5 in

NOTA: Uría se reserva el derecho de hacer cambios en la fabricación de sus artículos sin previo aviso. Asimismo en precios y disponibilidad.

NOTE: Uría reserves the right to make changes in the manufacturing of its products without advanced notice. Prices and availability subject to change.

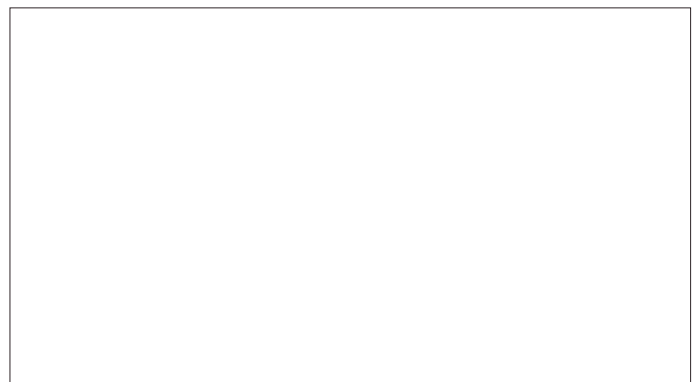

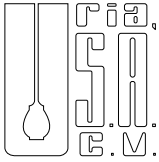

uría, s.a. de c.v.

uria@prodigy.net.mx

55 5272 9066 55 5272 9126 55 5272 9486 55 5273 3576

 55 3189 8670

 @uria.fabrica

 @uria.fabrica

Italianos 16

Col. El Paraíso

01130 Álvaro Obregón, Ciudad de México

MÉXICO

Lunes a viernes de 9:00 a 17:00

Monday to Friday from 9:00 to 17:00

Productos de Cocina





¡NUEVA CARACTERÍSTICA!
Capacidades marcadas
en el mango.

NEW FEATURE!
Capacities labeled
on handle



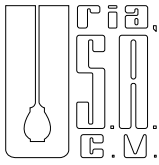

artículos de acero inoxidable
stainless steel products

clave 297, 297 C, 298, 298 C, 299, 299 BIS
item no. 300, 300 BIS, 301, 301 BIS, 302, 302 BIS
303, 303 BIS, 304 & 304 BIS

- 297 cucharón 30 ml.
- 297 C cucharón mango corto 30 ml.
- 298 cucharón 60 ml.
- 298 C cucharón mango corto 60 ml.
- 299 cucharón 90 ml.
- 299 BIS cucharón perforado
- 300 cucharón 165 ml.
- 300 BIS cucharón perforado
- 301 cucharón 225 ml.
- 301 BIS cucharón perforado
- 302 cucharón 360 ml.
- 302 BIS cucharón perforado
- 303 cucharón 600 ml.
- 303 BIS cucharón perforado
- 304 cucharón 900 ml.
- 304 BIS cucharón perforado

- 297 1 oz. ladle
- 297 C 1 oz. short handle ladle
- 298 2 oz. ladle
- 298 C 2 oz. short handle ladle
- 299 3 oz. ladle
- 299 BIS perforated ladle
- 300 5.5 oz. ladle
- 300 BIS perforated ladle
- 301 7.5 oz. ladle
- 301 BIS perforated ladle
- 302 12 oz. ladle
- 302 BIS perforated ladle
- 303 20 oz. ladle
- 303 BIS perforated ladle
- 304 30 oz. ladle
- 304 BIS perforated ladle

Estos cucharones de cocina tienen un mango de muy grueso calibre que los hace super resistentes; un gancho al final los hace antideslizables y para colgarlos de cualquier lugar. Los hay lisos y perforados.

These kitchen ladles have a heavy gauge handle that makes them very sturdy and a hook at the end for a good grip and to be hung anywhere. Available solid or perforated.

clave		material	capacidad (ml.)	medidas (mm.)		peso (kg.)	empaquete (caja de cartón)
liso	perforado			A	B		
297		acero inoxidable	30	45	280	.066	24 pzas. 1.80 kg. 120x450x95 mm.
297 C			30	45	170	.055	24 pzas. 1.53 kg. 120x450x95 mm.
298			60	60	280	.078	12 pzas. 1.16 kg. 120x450x95 mm.
298 C			60	60	170	.060	24 pzas. 1.77 kg. 120x450x95 mm.
299	299 BIS		90	80	280	.097	12 pzas. 1.40 kg. 120x450x95 mm.
300	300 BIS		165	90	355	.148	12 pzas. 2.14 kg. 165x510x125 mm.
301	301 BIS		225	100	355	.155	12 pzas. 2.23 kg. 165x510x125 mm.
302	302 BIS		360	120	395	.200	12 pzas. 3.00 kg. 210x630x190 mm.
303	303 BIS		600	140	430	.258	12 pzas. 3.60 kg. 210x630x190 mm.
304	304 BIS		900	160	465	.350	12 pzas. 4.45 kg. 210x630x190 mm.

item no.		material	capacity (fl.oz.)	dimensions (in.)		weight (lbs.)	packaging (cardboard box)
solid	perforated			A	B		
297		stainless steel	1	1.772	11.024	.15	24 pcs. 3.97 lbs. 4.7x17.7x3.7 in.
297 C			1	1.772	6.693	.12	24 pcs. 3.37 lbs. 4.7x17.7x3.7 in.
298			2	2.362	11.024	.17	12 pcs. 2.56 lbs. 4.7x17.7x3.7 in.
298 C			2	2.362	6.693	.13	24 pcs. 3.90 lbs. 4.7x17.7x3.7 in.
299	299 BIS		3	3.150	11.024	.21	12 pcs. 3.09 lbs. 4.7x17.7x3.7 in.
300	300 BIS		5.5	3.543	13.976	.33	12 pcs. 4.72 lbs. 6.5x20.1x4.9 in.
301	301 BIS		7.5	3.937	13.976	.34	12 pcs. 4.92 lbs. 6.5x20.1x4.9 in.
302	302 BIS		12	4.724	15.551	.44	12 pcs. 6.61 lbs. 8.3x24.8x7.5 in.
303	303 BIS		20	5.512	16.929	.57	12 pcs. 7.94 lbs. 8.3x24.8x7.5 in.
304	304 BIS		30	6.299	18.307	.77	12 pcs. 9.81 lbs. 8.3x24.8x7.5 in.

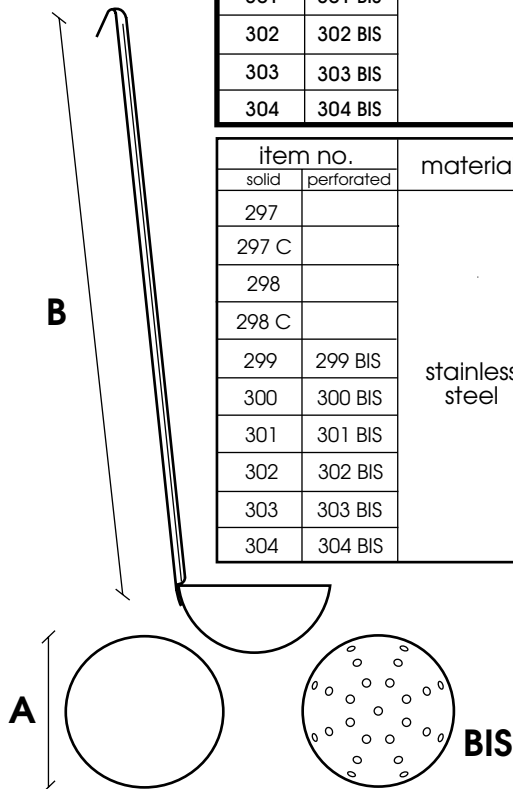

NOTA: Uría se reserva el derecho de hacer cambios en la fabricación de sus artículos sin previo aviso. Asimismo en precios y disponibilidad.

NOTE: Uría reserves the right to make changes in the manufacturing of its products without advanced notice. Prices and availability subject to change.



¡NUEVA CARACTERÍSTICA!
Capacidades marcadas
en el mango.

NEW FEATURE!
Capacities labeled
on handle

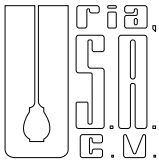

artículos de acero inoxidable
stainless steel products

clave 299 S, 300 S & 301 S
item no.

- 299 S cucharón sopero 90 ml.
- 300 S cucharón sopero 165 ml.
- 301 S cucharón sopero 225 ml.

Cucharones con un brillo excepcional y de mango estilizado para servir en la mesa. Tienen una perforación en el mango para colgarse.

- 299 S 3.0 oz. table ladle
- 300 S 5.5 oz. table ladle
- 301 S 7.5 oz. table ladle

With a mirrored finish and an elegantly shaped handle, these soup ladles are great for serving at the table. A hole in the handle lets them be easily hung.

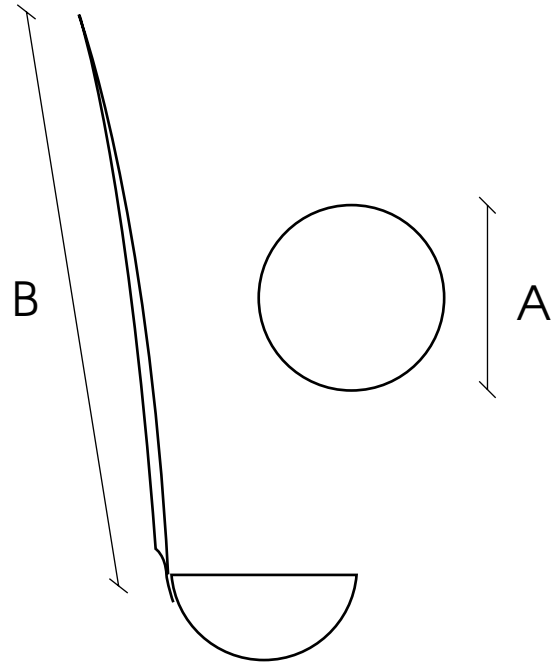

clave	material	capacidad (ml.)	medidas (mm.)		peso (kg.)	empaquete (caja de cartón)
			A	B		
299 S	acero inoxidable	90	80	245	.097	12 pzas. 1.40 kg. 120x450x95 mm.
300 S		165	90	245	.117	12 pzas. 1.65 kg. 120x450x95 mm.
301 S		225	100	245	.135	12 pzas. 1.83 kg. 120x450x95 mm.

item no.	material	capacity (fl. oz.)	dimensions (in.)		weight (lbs.)	packaging (cardboard box)
			A	B		
299 S	stainless steel	3	3.150	9.646	.21	12 pcs. 3.09 lbs. 4.7x17.7x3.7 in
300 S		5.5	3.543	9.646	.26	12 pcs. 3.64 lbs. 4.7x17.7x3.7 in
301 S		7.5	3.937	9.646	.30	12 pcs. 4.03 lbs. 4.7x17.7x3.7 in

NOTA: Uría se reserva el derecho de hacer cambios en la fabricación de sus artículos sin previo aviso. Asimismo en precios y disponibilidad.

NOTE: Uría reserves the right to make changes in the manufacturing of its products without advanced notice. Prices and availability subject to change.

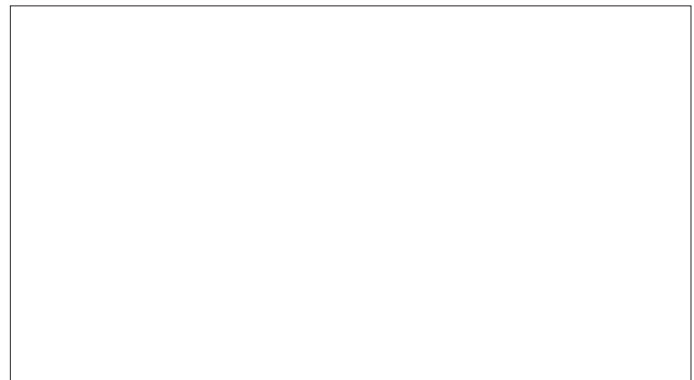



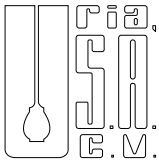

clave 305, 305 BIS, 306, 306 BIS, 307 & 307 BIS
 artículos de acero inoxidable
 stainless steel products

- 305 cuchara de servicio lisa chica
- 305 BIS cuchara de servicio perforada chlca
- 306 cuchara de servicio lisa mediana
- 306 BIS cuchara de servicio perforada mediana
- 307 cuchara de servicio lisa grande
- 307 BIS cuchara de servivclo perforada grande

- 305 small solid serving spoon
- 305 BIS smal perforated serving spoon
- 306 medium solid serving spoon
- 306 BIS medium perforated serving spoon
- 307 large solid serving spoon
- 307 BIS large perforated serving spoon

Las más bonitas y resistentes del mercado. Su pulido, capacidad y calibre las hace inigualables. ¡Sólo espere que no le aviente una, un chef de mal humor!

The most attractive and resistan in the market. Its finish, capacity and heavy gauge make them both unique and practical. Just hope that any angry chef does not throw one at you!

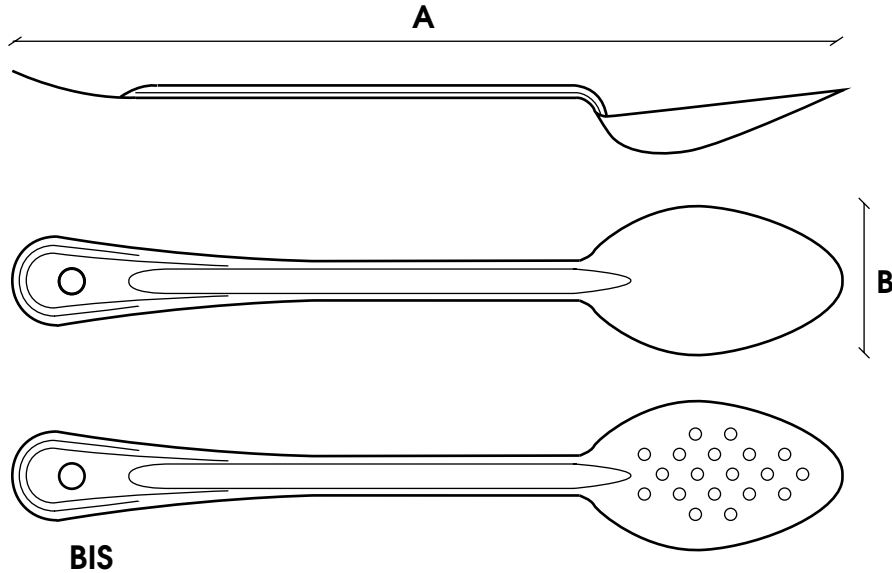

clave		material	capacidad (ml.)	medidas (mm.)		peso (kg.)	empaquete (caja de cartón)
lisa	perforada			A	B		
305	305 BIS	acero inoxidable	45	300	69	.106	48 pzas. 5.33 kg. 120x450x95 mm.
306	306 BIS			350	69	.114	48 pzas. 5.74 kg. 120x450x95 mm.
307	307 BIS			400	69	.120	48 pzas. 6.04 kg. 120x450x95 mm.

item no.		material	capacity (fl. oz.)	dimensions (in.)		weight (lbs)	packaging (cardboard box)
solid	perforated			A	B		
305	305 BIS	stainless steel	1.5	11.811	2.717	.23	48 pcs. 11.75 lbs. 4.7x17.7x3.7 in
306	306 BIS			13.780	2.717	.25	48 pcs. 12.65 lbs. 4.7x17.7x3.7 in
307	307 BIS			15.748	2.717	.26	48 pcs. 13.32 lbs. 4.7x17.7x3.7 in

NOTA: Uría se reserva el derecho de hacer cambios en la fabricación de sus artículos sin previo aviso. Asimismo en precios y disponibilidad.

NOTE: Uría reserves the right to make changes in the manufacturing of its products without advanced notice. Prices and availability subject to change.

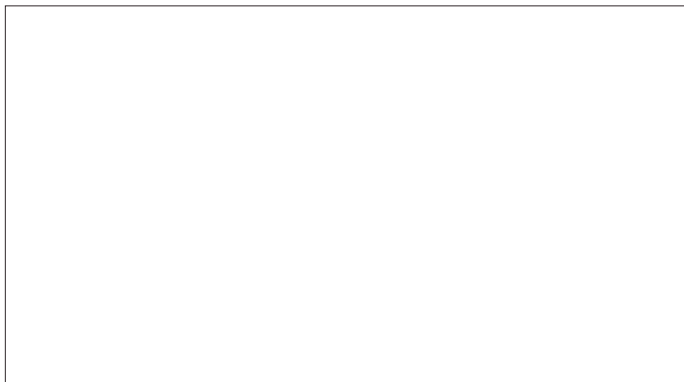





artículos de acero inoxidable
stainless steel products

clave
item no.
308 & 308 BIS

308 volteador rígido liso 308 BIS volteador rígido ranurado

Si usted va a freír comida muy pesada o en una cacerola profunda, éste es el volteador perfecto a usar. Tiene una paleta y un mango rígidos para tal efecto.

Adquiéralo liso o ranurado.

clave	material	peso (kg.)	empaque (caja de cartón)
308	acero inoxidable	.148	18 pzas. 3.02 kg. 165x510x125 mm.
308 BIS		.140	

308 rigid turner 308 BIS rigid slotted turner

If you need to fry heavy foods or in deep pots, these are the turners to use. They come with a rigid blade and a handle with a hook, in solid or slotted.

item no.	material	weight (lbs.)	packaging (cardboard box)
308	stainless steel	.33	18 pcs. 6.66 lbs. 6.5x20.1x4.9 in
308 BIS		.31	

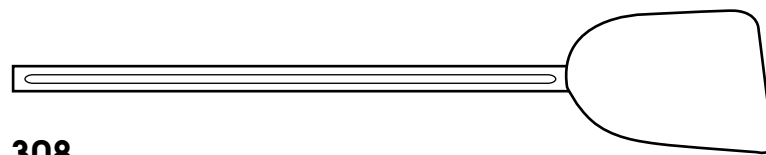

308

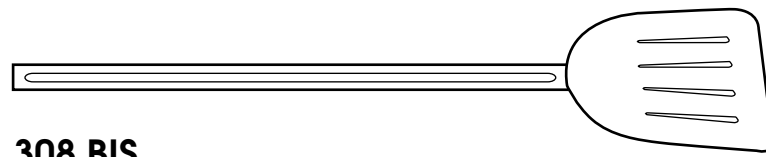

308 BIS

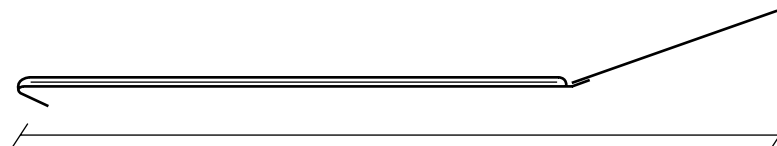

460 mm
(18.110")

NOTA: Uría se reserva el derecho de hacer cambios en la fabricación de sus artículos sin previo aviso. Asimismo en precios y disponibilidad.

NOTE: Uría reserves the right to make changes in the manufacturing of its products without advanced notice. Prices and availability subject to change.



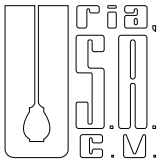

artículos de acero inoxidable
stainless steel products

clave
item no.
309 & 309 BIS

309 volteador flexible liso 309 BIS volteador flexible ranurado

Este artículo tiene un mango de grueso calibre y una paleta flexible, ideal para voltear cualquier alimento. También lo puede usar para raspar su plancha de freído, ya que está hecho con acero inoxidable de la mejor calidad.

clave	material	peso (kg.)	empaque (caja de cartón)
309	acero inoxidable	.125	24 pzas. 3.16 kg. 120x450x95 mm.
309 BIS		.118	

309 flexible turner 309 BIS flexible slotted turner

This product has a heavy gauge handle and a flexible blade (available in solid or slotted) to easily turn any type of food. Because of its high quality stainless steel, it can also be used to scrape and clean your frying surface.

item no.	material	weight (lbs.)	packaging (cardboard box)
309	stainless steel	.28	24 pcs. 6.97 lbs. 4.7x17.7x3.7 in
309 BIS		.26	

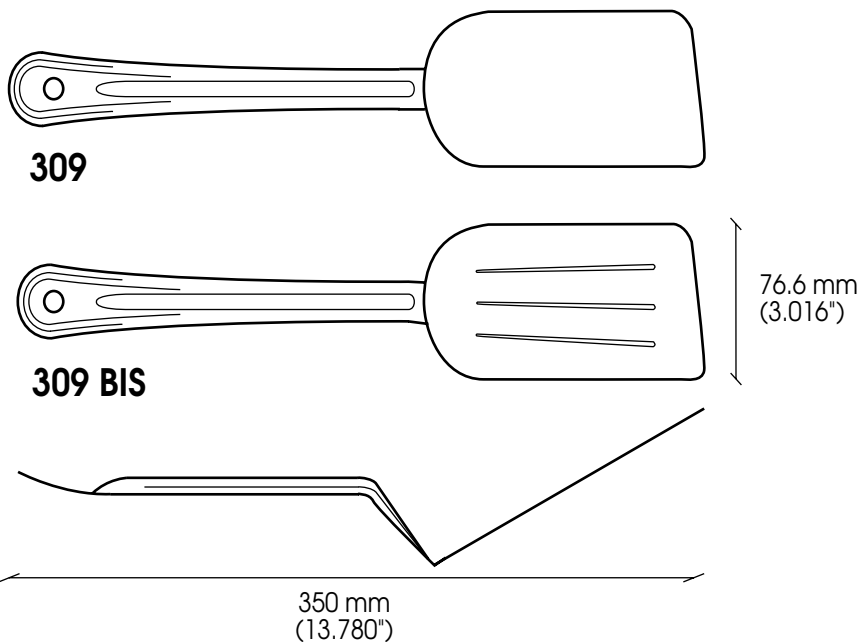

NOTA: Uría se reserva el derecho de hacer cambios en la fabricación de sus artículos sin previo aviso. Asimismo en precios y disponibilidad.

NOTE: Uría reserves the right to make changes in the manufacturing of its products without advanced notice. Prices and availability subject to change.

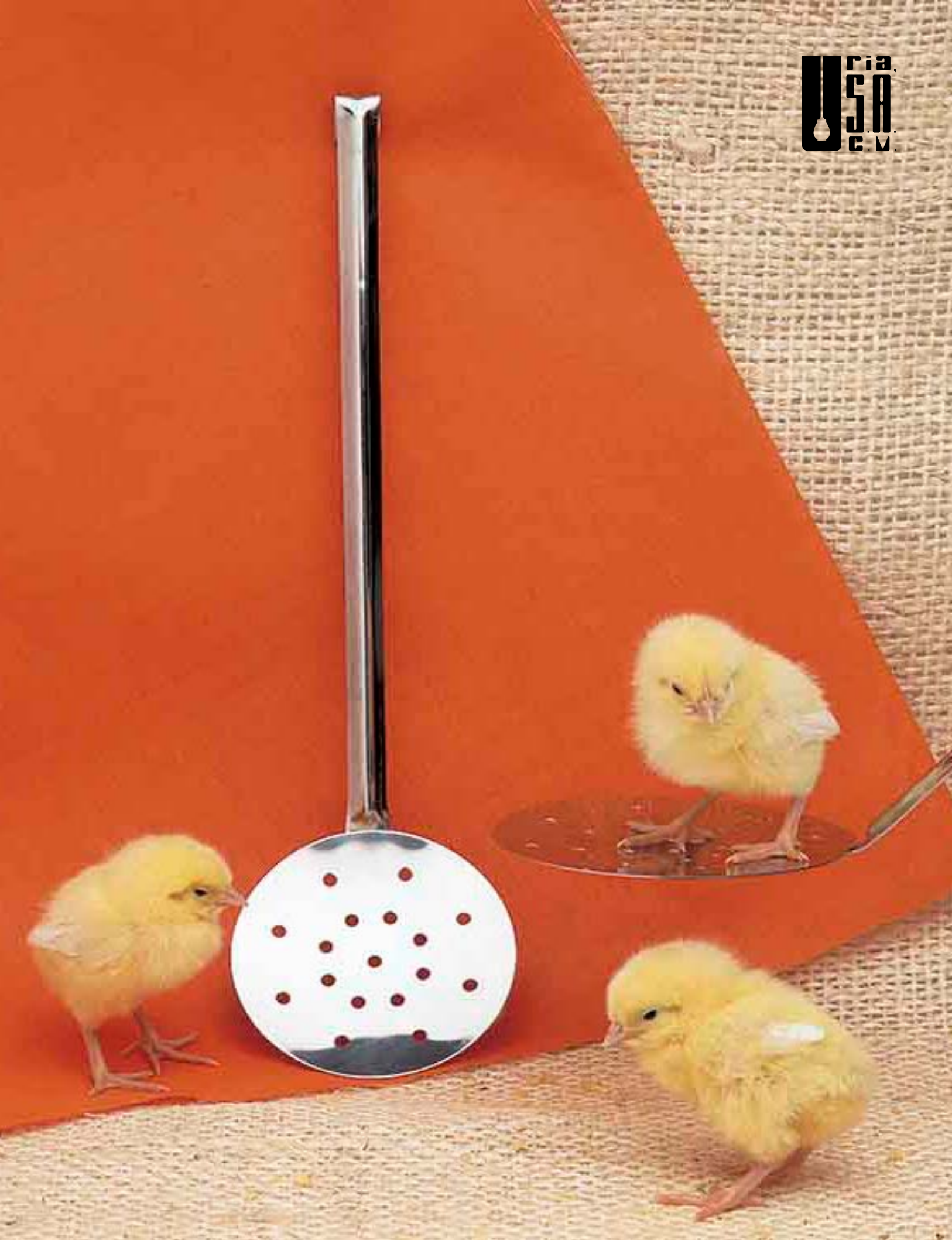

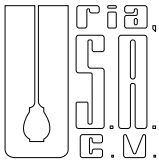

artículos de acero inoxidable
stainless steel products

clave 310, 311, 312 & 313
item no.

- 310 espumadera chica
- 311 espumadera mediana
- 312 espumadera grande
- 313 espumadera extragrande

Pareciera que estos artículos fueron inventados para la tradicional comida mexicana. Excelentes para freír tortillas, sopes, quesadillas, etc. Muy resistentes y durables.

- 310 small skimmer
- 311 medium skimmer
- 312 large skimmer
- 313 extra large skimmer

It would appear that these skimmers were especially designed for mexican food. Excellent for frying tortillas, quesadillas, onion rings, french fries, etc. They are resistant and long lasting.

clave	material	medidas (mm.)		peso (kg.)	empaquete (caja de cartón)
		A	B		
310	acero inoxidable	100	370	.085	18 pzas. 1.78 kg. 120x450x95 mm
311		120	460	.135	18 pzas. 2.78 kg. 165x510x125 mm.
312		140	520	.175	24 pzas. 5.05 kg. 210x630x190 mm.
313		160	570	.205	24 pzas. 5.65 kg. 210x630x190 mm.

item no.	material	dimension (in.)		weight (lbs.)	packaging (cardboard box)
		A	B		
310	stainless steel	3.937	14.567	.19	18 pcs. 3.92 lbs. 4.7x17.7x3.7 in
311		4.724	18.110	.30	18 pcs. 6.13 lbs. 6.5x20.1x4.9 in
312		5.512	20.472	.39	24 pcs. 11.13 lbs. 8.3x24.8x7.5 in
313		6.299	22.441	.45	24 pcs. 12.46 lbs. 8.3x24.8x7.5 in

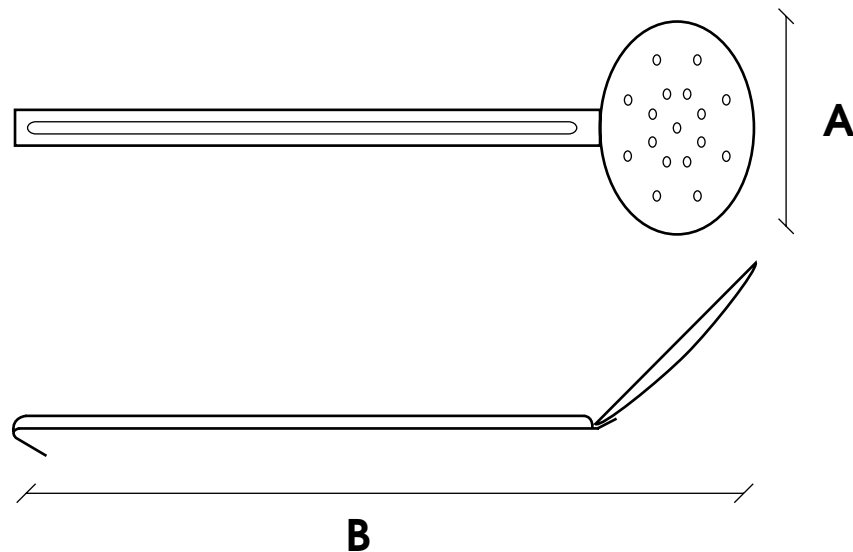

NOTA: Uría se reserva el derecho de hacer cambios en la fabricación de sus artículos sin previo aviso. Asimismo en precios y disponibilidad.

NOTE: Uría reserves the right to make changes in the manufacturing of its products without advanced notice. Prices and availability subject to change.

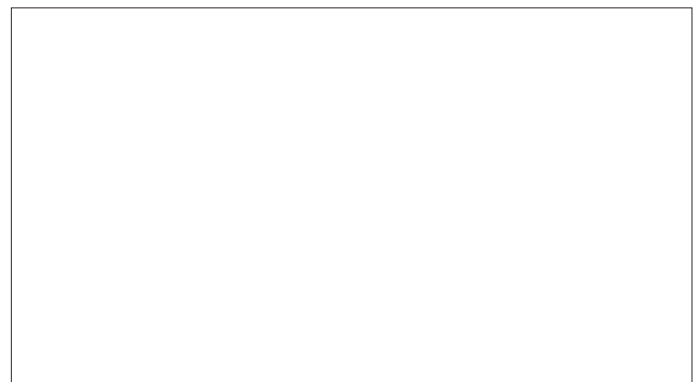

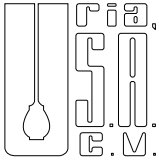

uría, s.a. de c.v.

uria@prodigy.net.mx

55 5272 9066 55 5272 9126 55 5272 9486 55 5273 3576

 55 3189 8670

 @uria.fabrica

 @uria.fabrica

Italianos 16

Col. El Paraíso

01130 Álvaro Obregón, Ciudad de México

MÉXICO

Lunes a viernes de 9:00 a 17:00

Monday to Friday from 9:00 to 17:00

Pinzas



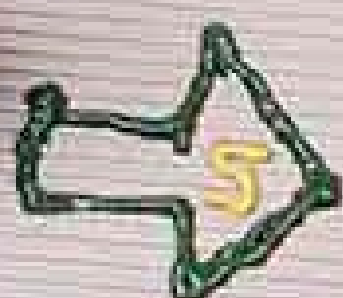

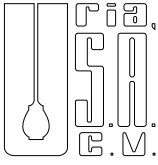

artículos de acero inoxidable
stainless steel products

clave
item no. 160

160 pinzas picnic

Fabricado en acero inoxidable de gran calidad y grueso calibre para larga duración, es el producto realmente útil en sus días de campo, comidas en Jardín, campamentos o la cocina.

Es un verdadero todo en uno pues en una de sus piezas tiene volteador, cuchillo y destapador. En la otra, abrelatas y trínche. ¡ ENSÁMBLALAS Y TIENES UNAS PINZAS !
Vienen en una práctica caja individual.

160 barbecue tongs

Manufactured from heavy duty, long lasting stainless steel, this is a multi-purpose product for picnics, barbecues, camping trips or in the kitchen.

A real versatile product that consists of two parts. One of them has a turner, a knife and a bottle opener. The other one, a can opener and a fork.

¡ ASSEMBLE THEM TOGETHER AND THEY BECOME TONGS !

This product is individually packed.

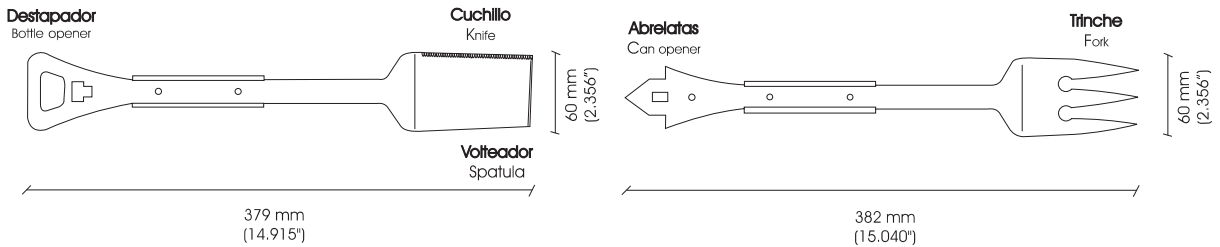

clave	material	peso (kg.)	caja individual (cartón)	empaques (caja de cartón)
160	acero inoxidable	.29	.41 kg. 125x415x45 mm.	12 cajas individuales 5.52 kg. 310 x 440 x 290 mm.

item no.	material	weight (lbs.)	individual box (cardboard)	packaging (cardboard box)
160	stainless steel	.64	.90 lbs. 4.9 x 16.3 x 1.8 in.	12 individual boxes 12.17 lbs. 12.2 x 17.3 x 11.4 in.

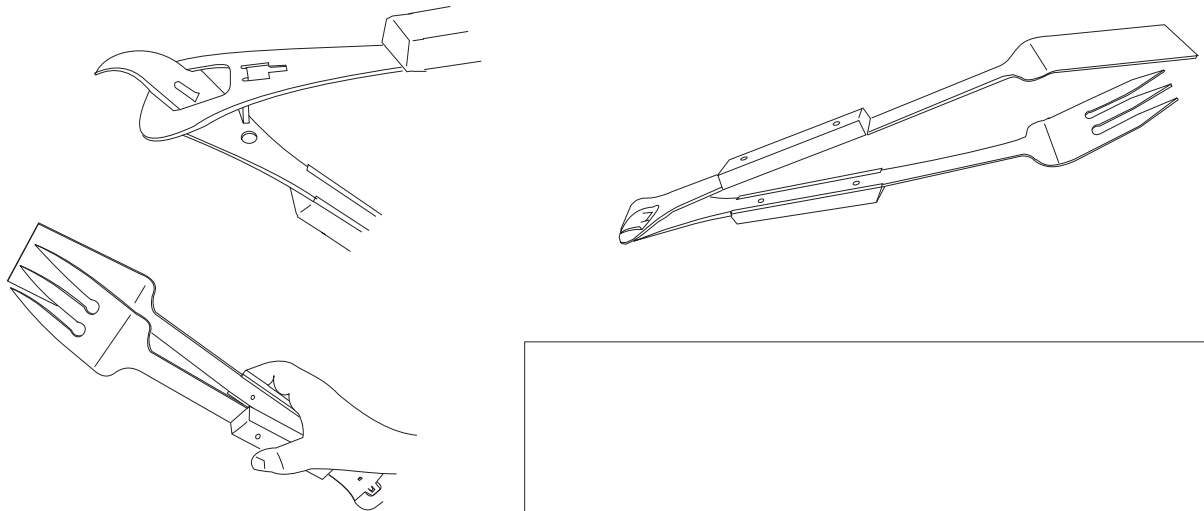

NOTA: Uría se reserva el derecho de hacer cambios en la fabricación de sus artículos sin previo aviso. Asimismo en precios y disponibilidad.

NOTE: Uría reserves the right to make changes in the manufacturing of its products without advanced notice. Prices and availability subject to change.



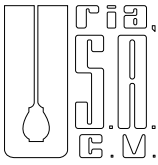

artículos de acero inoxidable
stainless steel products

clave
item no. **165**

165 pinzas multiusos

Debido al gran éxito de nuestras pinzas picnic, decidimos fabricar las multiusos para manejar un tenedor, un cuchillo, un abrelatas-destapador, una cuchara y unas pinzas EN UNA SOLA MANO.

Muy útiles para meseros, montañistas, comidas en Jardín o la cocina. Empacadas individualmente.

165 multipurpose tongs

Due to the great succes of our barbecue tongs, Uria decided to manufacture these new ones. IN JUST ONE HAND you can handle a fork, a knife, a can-bottle opener, a spoon and the tongs.

Very useful for waiters and waitresses, picnics, mountaniieers or the kitchen. These tongs are individually packed.

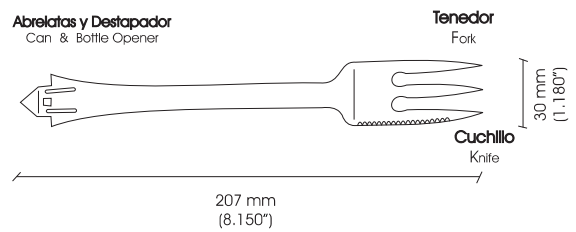
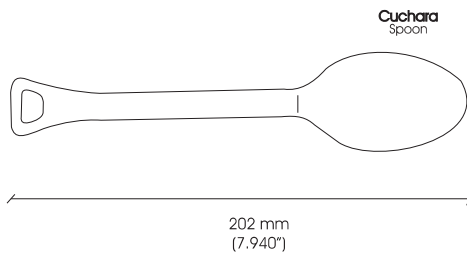

clave	material	peso (kg.)	caja individual (cartón)	empaques (caja de cartón)
165	acero inoxidable	.09	.10 kg. 80 x 220 x 25 mm.	8 cajas individuales .92 kg. 120 x 450 x 95 mm.

item no.	material	weight (lbs.)	individual box (cardboard)	packaging (cardboard box)
165	stainless steel	.20	.22 lbs. 3.1 x 8.7 x 1 in.	8 individual boxes 2.02 lbs. 4.7 x 17.7 x 3.7 in.

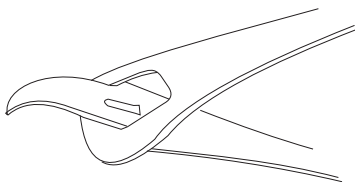
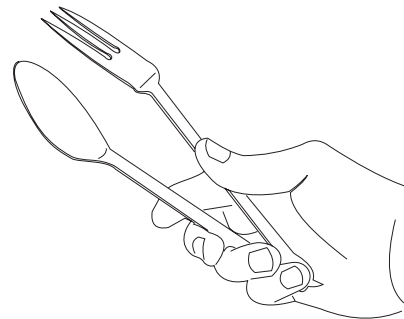
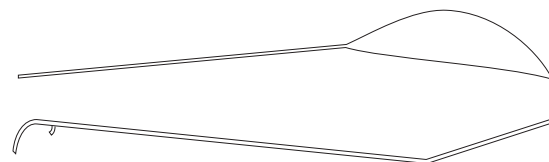

NOTA: Uria se reserva el derecho de hacer cambios en la fabricación de sus artículos sin previo aviso. Asimismo en precios y disponibilidad.

NOTE: Uria reserves the right to make changes in the manufacturing of its products without advanced notice. Prices and availability subject to change.

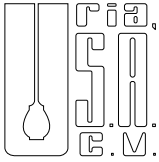

uría, s.a. de c.v.

uria@prodigy.net.mx

55 5272 9066 55 5272 9126 55 5272 9486 55 5273 3576

 55 3189 8670

 @uria.fabrica

 @uria.fabrica

Italianos 16

Col. El Paraíso

01130 Álvaro Obregón, Ciudad de México

MÉXICO

Lunes a viernes de 9:00 a 17:00

Monday to Friday from 9:00 to 17:00

Productos de Mesa





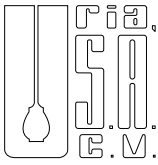

artículos de acero inoxidable
stainless steel products

clave
item no. **130**

130 cenicero

Distinga sus mesas y a todo su restaurant con este elegante cenicero. También encontrará que es **IRROMPIBLE** y apliable, lo que los ceniceros de vidrio no le ofrecen.

Se vende individualmente.

clave	material	peso (kg.)
130	acero inoxidable	.046

130 ash tray

Distinguish your tables and restaurant with this elegant ash tray. Compared to the typical glass ash tray, you will find it is **UNBREAKABLE** and stackable.

Sold individually.

item no.	material	weight (lbs.)
130	stainless steel	.10

109.2 mm
(4.300")

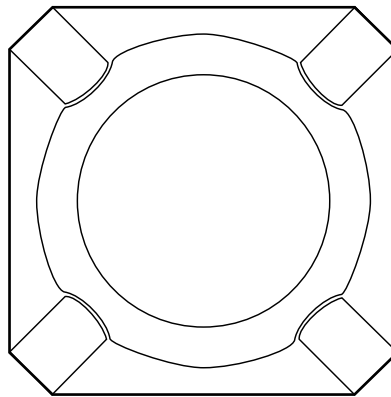

15 mm
(.591")

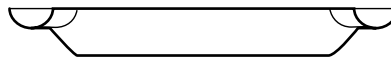

NOTA: Uría se reserva el derecho de hacer cambios en la fabricación de sus artículos sin previo aviso. Asimismo en precios y disponibilidad.

NOTE: Uría reserves the right to make changes in the manufacturing of its products without advanced notice. Prices and availability subject to change.

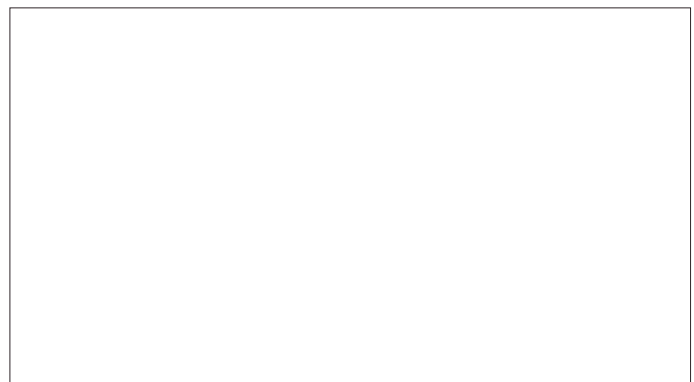



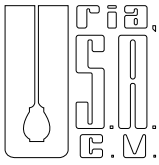

artículos de acero inoxidable
stainless steel products

clave item no. 140 & 140 BIS

140 platito para mantequilla o bolsita de té
140 BIS platito para mantequilla chico o bolsita de té

Estos bellos mantequilleros cuadrados combinarán a la perfección con cualquier tipo de loza y cubiertos de acero inoxidable o plata. Recuerde que la mayoría de los cuchillos para mantequilla son de acero inoxidable.
 Se venden por pieza.

clave	recipiente	peso (kg.)
140	acero inoxidable	.019
140 BIS		.015

140 butter or tea bag chip
140 BIS small butter or tea bag chip

These attractive square butter chips will combine perfectly with any type of place setting, especially with the stainless steel butter knife.
 Sold individually.

item no.	container	weight (lbs.)
140	stainless steel	.04
140 BIS		.03

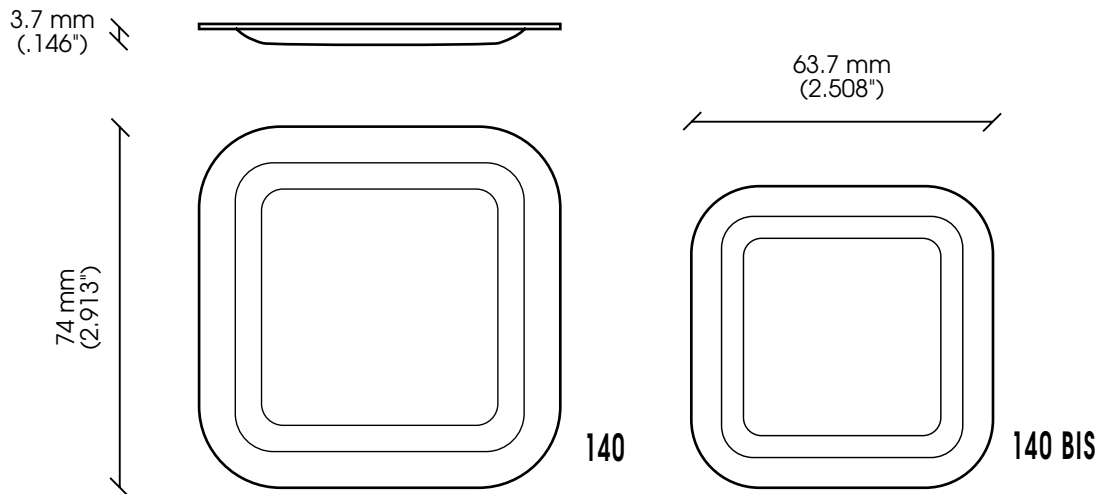

NOTA: Uría se reserva el derecho de hacer cambios en la fabricación de sus artículos sin previo aviso. Asimismo en precios y disponibilidad.

NOTE: Uría reserves the right to make changes in the manufacturing of its products without advanced notice. Prices and availability subject to change.

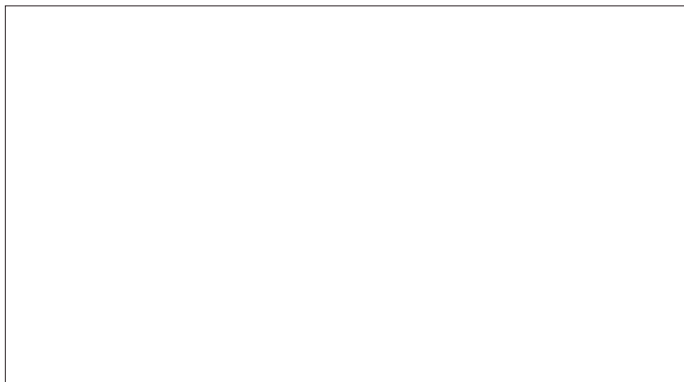



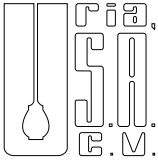

artículos de acero inoxidable
stainless steel products

clave
item no. **145**

145 pollito

Perfecto para limpiar migajas de una mesa con mantel de tela.
¡Atención meseros!, guárdenlo comodamente en el bolsillo de la camisa, filipina o chaleco. Por su material y acabado, tiene una elegancia sin igual.
Imprima en ellos los datos de su restaurant o negocio, y utilícelos como un efectivo medio publicitario.

145 table crumber

Helps maintain table tops free of crumbs.
Attention waiters!, it's very handy and includes a pocket clip.
Elegant due to its stainless steel manufacturing and finish.
Use them for publicity, printing the data of your business or restaurant on them.

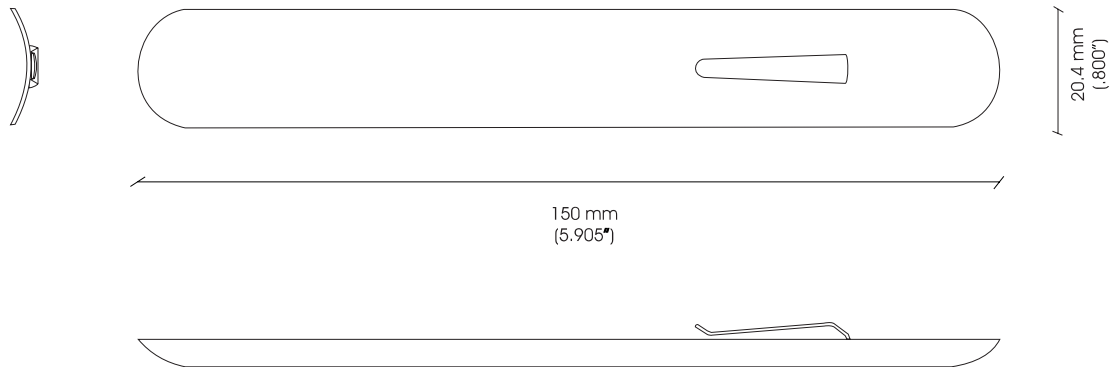

clave	material	peso (kg)	empaque (caja de cartón)
145	acero inoxidable	.018	500 pzas. 9.40 kg. 165x510x125 mm.

item no.	material	peso (kg)	empaque (caja de cartón)
145	stainless steel	.39	500 pcs. 20.72 lbs. 6.5x20.1x4.9 in.

NOTA: Uría se reserva el derecho de hacer cambios en la fabricación de sus artículos sin previo aviso. Asimismo en precios y disponibilidad.

NOTE: Uría reserves the right to make changes in the manufacturing of its products without advanced notice. Prices and availability subject to change.

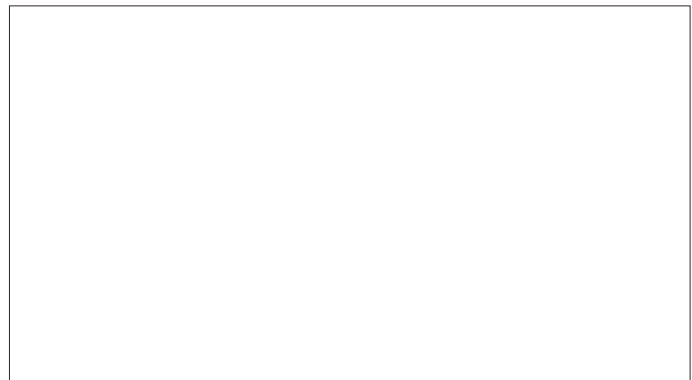



uría



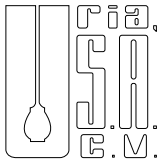

artículos de acero inoxidable
stainless steel products

clave
item no. **146**

146 pollito "stylo"

Mantenga limpias las mesas de su restaurant con "estilo".

Su moderno diseño distinguirá a su personal.

Imprima en ellos datos de su restaurant o negocio, y utilícelos como un efectivo medio publicitario.

146 "stylo" table crumber

Keep your restaurant's tables cloths clean with "style".

Distinguish your waiters and waitresses with this modern design table crumber.

Use them for publicity, printing the data of your business or restaurant on them.

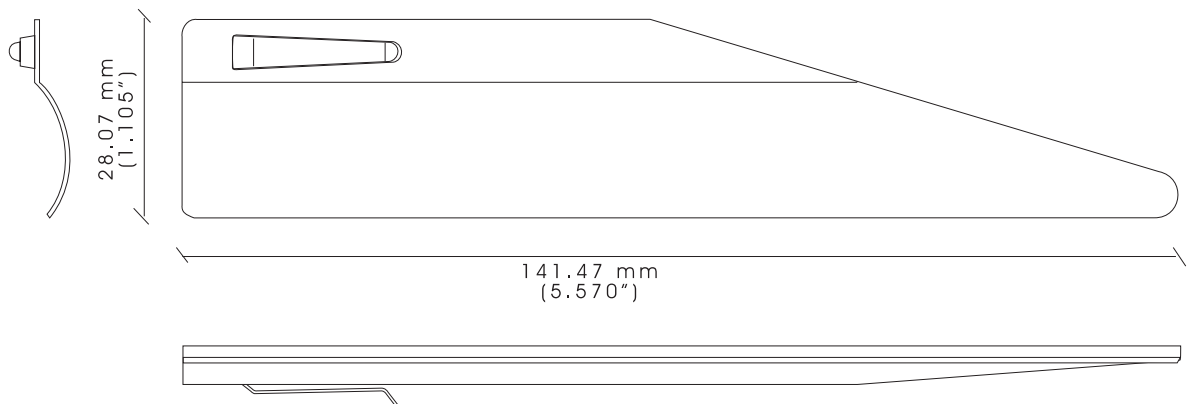

clave	material	peso (kg)	empaque (caja de cartón)
146	acero inoxidable	.019	500 pzas. 9.40 kg. 165x510x125 mm.

item no.	material	peso (kg)	empaque (caja de cartón)
146	stainless steel	.42	500 pcs. 20.72 lbs. 6.5x20.1x4.9 in.

NOTA: Uría se reserva el derecho de hacer cambios en la fabricación de sus artículos sin previo aviso. Asimismo en precios y disponibilidad.

NOTE: Uría reserves the right to make changes in the manufacturing of its products without advanced notice. Prices and availability subject to change.

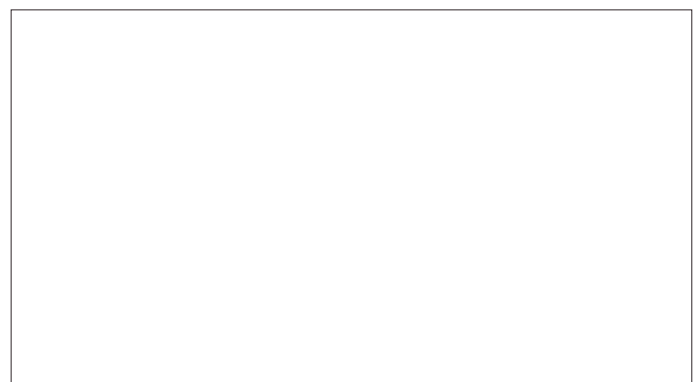



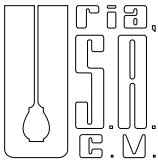

artículos de acero inoxidable
stainless steel products

clave
item no. **150**

150 servilletero con compartimento

IDEAS PARA EL USO DEL PRODUCTO

- * Coloque su menú o promociones parados detrás de las servilletas, el servilletero no se caerá, es muy estable.
- * Use el compartimento para bolsitas de: azúcar, endulzante artificial, café, crema en polvo, té, etc. Es ideal como paillero y con pequeñas flores naturales o artificiales dará un fino ambiente.
- * Grave o pegue su logotipo al frente.

clave	material	peso (kg.)	empaquete (caja de cartón)
150	acero inoxidable	.14	24 pzas. 3.78 kg. 230x230x225 mm.

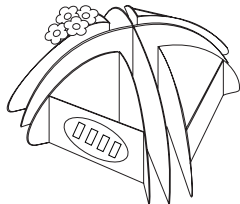
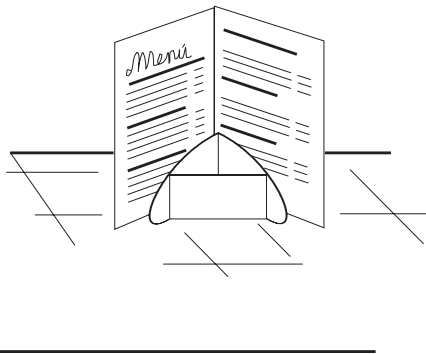
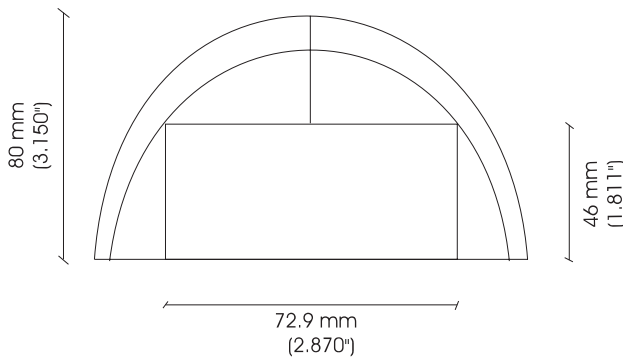

NOTA: Uría se reserva el derecho de hacer cambios en la fabricación de sus artículos sin previo aviso. Asimismo en precios y disponibilidad.

NOTE: Uría reserves the right to make changes in the manufacturing of its products without advanced notice. Prices and availability subject to change.

150 napkin holder with compartment

PRODUCT USE IDEAS

- * Stand your menu or promotions behind the napkins, the napkin holder won't fall, is very stable.
- * Use the compartment for individual portions of: sugar, artificial sweetener, coffee, coffee creamer, tea, etc. It's ideal as a toothpick dispenser or you can give a touch of class by putting small natural or artificial flowers in it.
- * Engrave or adhere your logo on the front.

item no.	material	weight (lbs.)	packaging (cardboard box)
150	stainless steel	.31	24 pcs. 8.33 lbs. 9.0x9.0x8.9 in..

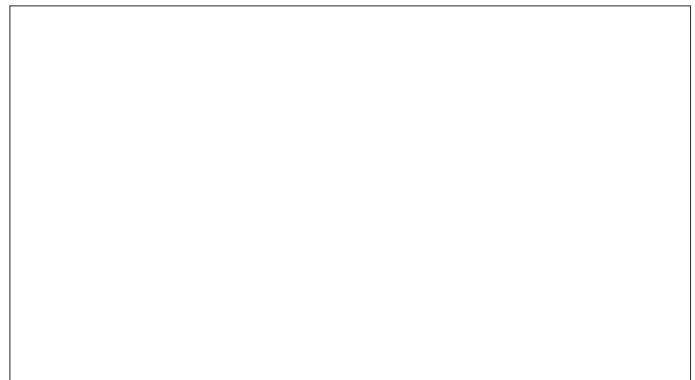
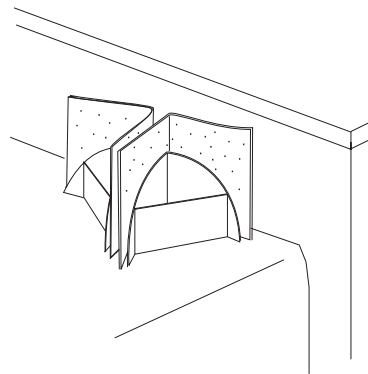
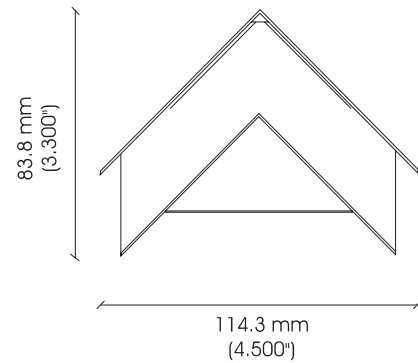



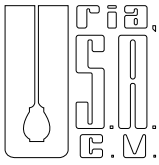

artículos de acero inoxidable
stainless steel products

clave item no. 169, 170, 171 & 172

169 copa coctelera chica
170 copa coctelera mediana
171 copa coctelera grande
172 copa coctelera grande con arillo

Ideales para servir fruta, mariscos y helado. Al artículo clave 172 se le pone hielo, luego el arillo y finalmente el recipiente de vidrio para mantener el cocktail frío.

169 small cocktail bowl
 170 medium cocktail bowl
 171 large cocktail bowl
 172 large cocktail bowl with ring

Ideal for fruit, seafood or ice-cream.

Put ice inside the bowl item no. 172, cover it with the ring and a glass bowl in order to maintain the cocktail cold.

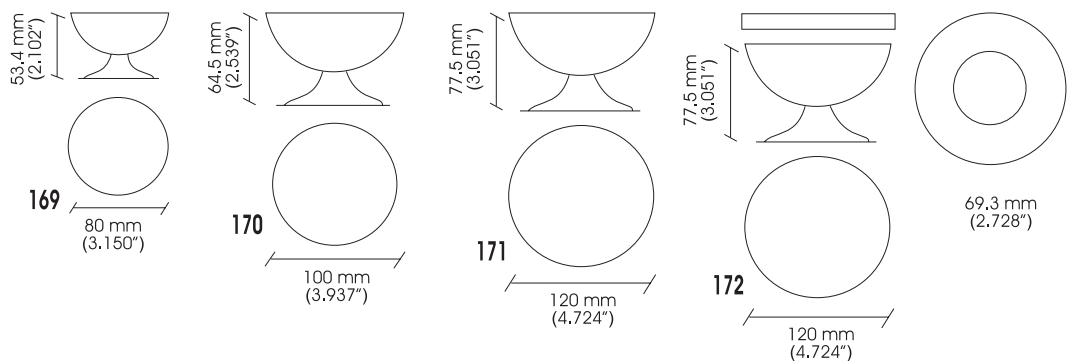

clave	material	capacidad (ml.)	peso (kg.)	empaque (caja de cartón)
169	acero inoxidable	90	.083	24 pzas. 2.20 kg. 230x230x170 mm.
170		225	.120	12 pzas. 1.73 kg. 230x230x225 mm.
171		360	.150	12 pzas. 2.08 kg. 230x230x225 mm.
172		360	.220	12 pzas. 3.20 kg. 230x230x225 mm.

item no.	material	capacity (fl. oz.)	weight (lbs.)	packaging (cardboard box)
169	stainless steel	3	.18	24 pzas. 4.85 lbs. 9x9x6.7 in.
170		7.5	.26	12 pzas. 3.81 lbs. 9x9x8.9 in.
171		12	.33	12 pzas. 4.60 lbs. 9x9x8.9 in.
172		12	.49	12 pzas. 7.05 lbs. 9x9x8.9 in.

NOTA: Uría se reserva el derecho de hacer cambios en la fabricación de sus artículos sin previo aviso. Asimismo en precios y disponibilidad.

NOTE: Uría reserves the right to make changes in the manufacturing of its products without advanced notice. Prices and availability subject to change.



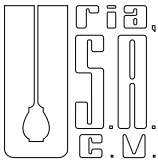

artículos de acero inoxidable
stainless steel products

clave
item no. **182**

182 trinchamango

Perfecto para usarse también con elote.

- 1) Lave muy bien el mango.
- 2) Inserte el trinchamango en la base del hueso.
- 3) Con un cuchillo, corte la cáscara en tiras; pélelo de abajo hacia la punta, para que la menor cantidad de fruta se quede en la cáscara.
- 4) ¡DISFRÚTELO SIN ENSUCIARSE!

182 mango fork

Ideal for corn as well.

- 1) Wash the mango.
- 2) Insert fork into stem base.
- 3) Slit the peeling with a knife and peel away from the bottom to the top of the mango in order to peel away the peeling only, not the fruit.
- 4) ENJOY IT WITHOUT THE MESS!

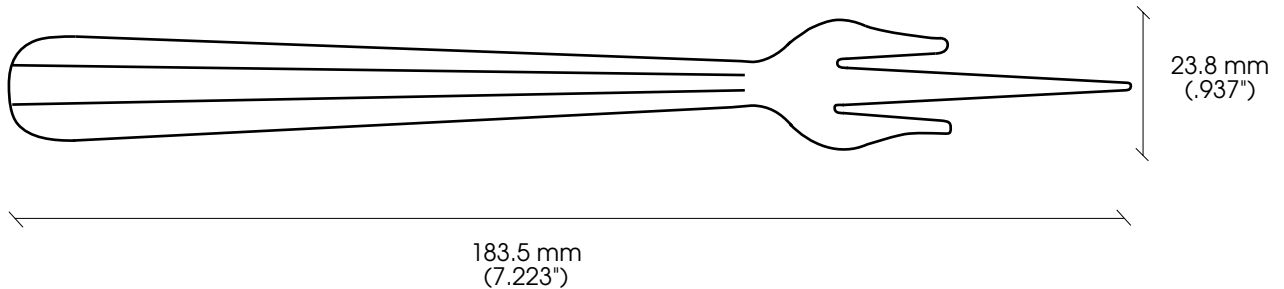

clave	material	peso (kg)	empaque (caja de cartón)
182	acero inoxidable	.02	600 pzas. 11.75 kg. 120x450x95 mm.

item no.	material	peso (kg)	empaque (caja de cartón)
182	stainless steel	.04	600 pcs. 25.90 lbs. 4.7x17.7x3.7 in.

NOTA: Uría se reserva el derecho de hacer cambios en la fabricación de sus artículos sin previo aviso. Asimismo en precios y disponibilidad.

NOTE: Uría reserves the right to make changes in the manufacturing of its products without advanced notice. Prices and availability subject to change.



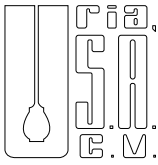

artículos de acero inoxidable
stainless steel products

clave
item no. **320, 321 & 322**

320 salsera o flanera chica
321 salsera o flanera mediana
322 salsera o flanera grande

Fabricamos estas salseras para que las use de diferentes maneras. Sus tres tamaños y su gran calidad de acero inoxidable, le permitirá usarlas con salsas, aderezos o condimentos; y en postres como flan, mermeladas o helados.

320 small sauce cup
321 medium sauce cup
322 large sauce cup

We manufacture these sauce cups for a wide variety of uses. Their three different sizes and high quality stainless steel will allow you to use them for hot sauces, dressings or condiments and for desserts such as ice-cream, custard, jello, etc.

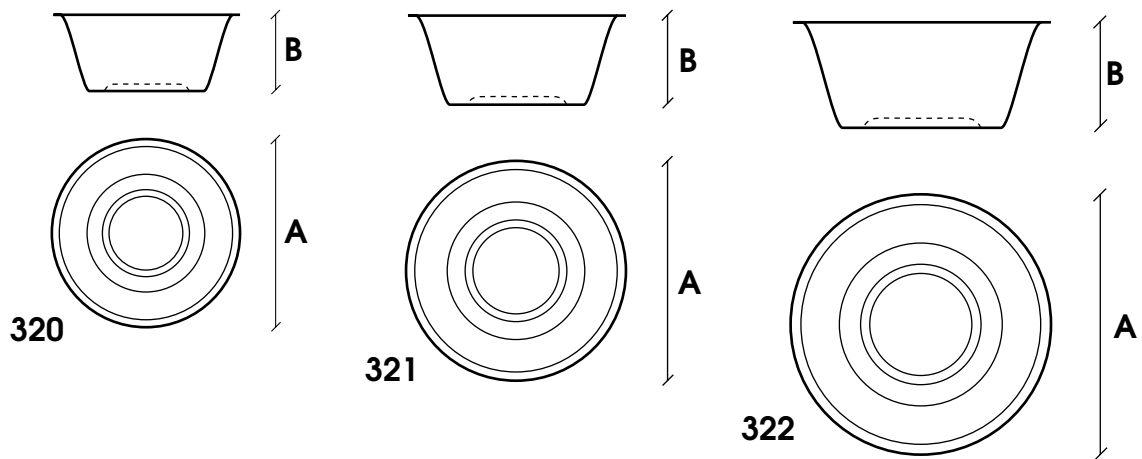

clave	material	capacidad (ml.)	medidas (mm.)		peso (kg.)
			A	B	
320	acero inoxidable	100	90	34	.035
321		150	100	37	.044
322		200	110	39	.053

item no.	material	capacity (fl. oz.)	dimensions (in.)		weight (lbs.)
			A	B	
320	stainless steel	3.3	3.543	1.339	.08
321		5	3.937	1.457	.10
322		6.7	4.331	1.535	.12

NOTA: Uría se reserva el derecho de hacer cambios en la fabricación de sus artículos sin previo aviso. Asimismo en precios y disponibilidad.

NOTE: Uría reserves the right to make changes in the manufacturing of its products without advanced notice. Prices and availability subject to change.

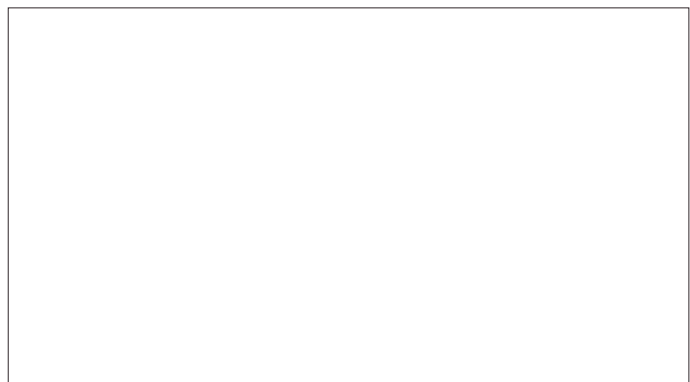

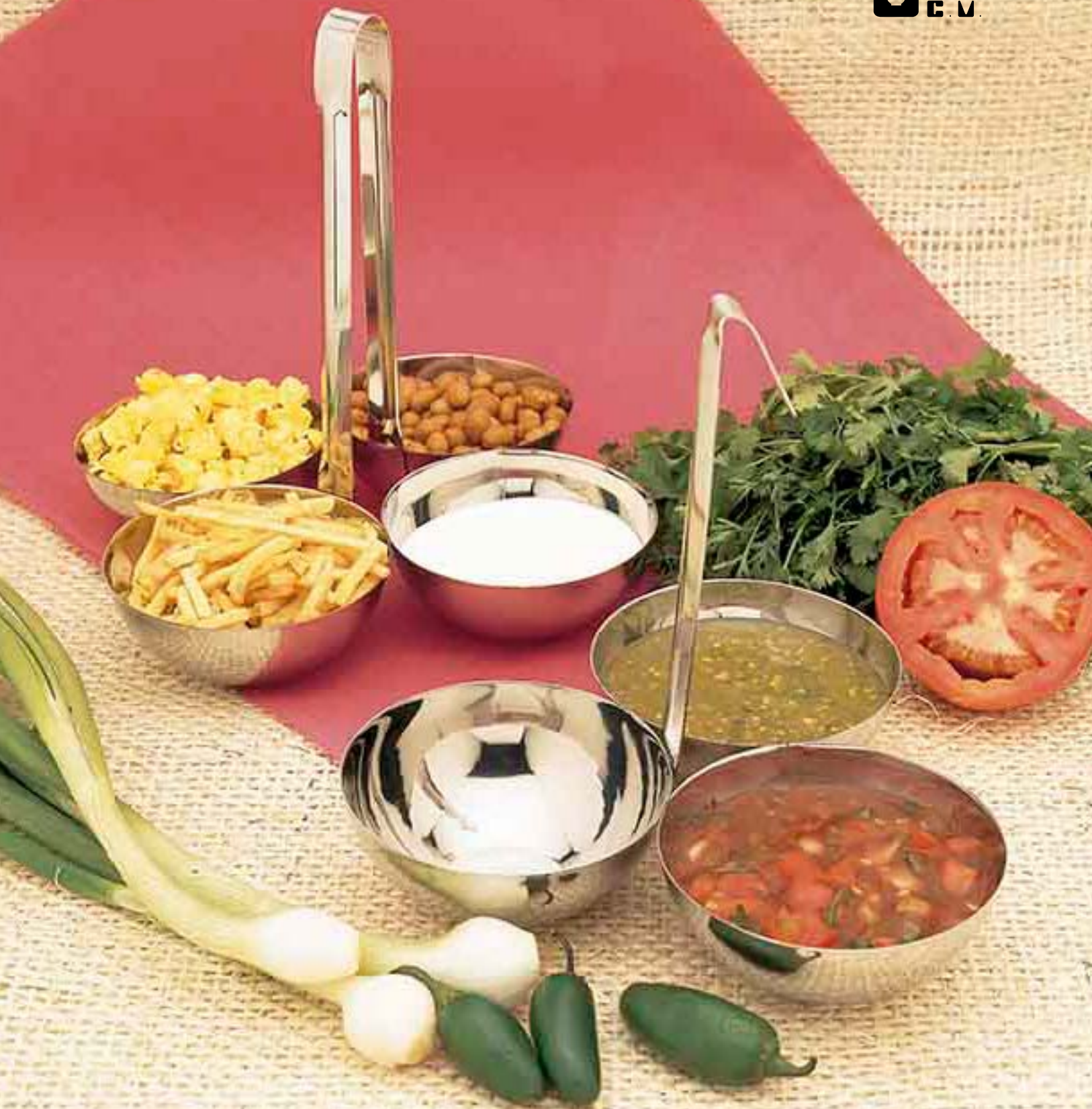

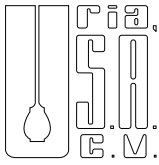

artículos de acero inoxidable
stainless steel products

clave
item no.
330, 331, 332 & 333

- 330 servidor de 3 recipientes chico
- 331 servidor de 4 recipientes chico
- 332 servidor de 3 recipientes grande
- 333 servidor de 4 recipientes grande

Estos originales servidores están hechos totalmente de acero inoxidable, lo cual elimina el alambre cromado que tienen los de nuestra competencia y que se oxida con facilidad.

Utilícelos para salsa, condimentos de sopas, aderezos, botanas y muchas cosas más.

- 330 small triple condiment server
- 331 small cuadruple condiment server
- 332 large triple condiment server
- 333 large cuadruple condiment server

These condiment servers are manufactured completely in stainless steel which eliminates the use of chromed wire that rusts easily like those of our competitors. Their versatile applications include hot sauces, dressings, toppings and any kind of condiments.

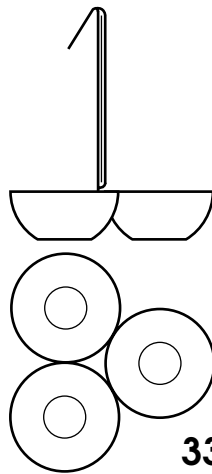

330 & 332

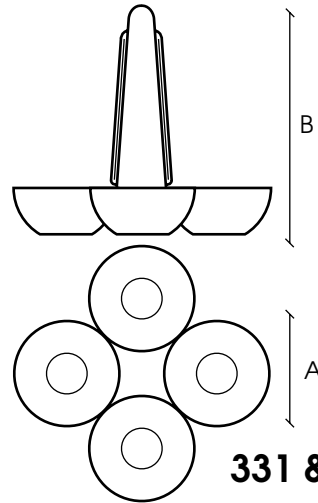

331 & 333

clave	material	capacidad recipiente (ml.)	medidas (mm.)		peso (kg.)	empaque (caja de cartón)
			A	B		
330	acero inoxidable	150	90	195	.250	12 pzas. 4.00 kg. 330x400x250 mm.
331		150	90	220	.335	12 pzas. 5.10 kg. 330x400x250 mm.
332		200	100	205	.260	10 pzas. 3.30 kg. 330x400x250 mm.
333		200	100	225	.350	10 pzas. 4.30 kg. 330x400x250 mm.

item no.	material	capacity per container (fl.oz)	dimensions (in)		weight (lbs.)	packaging (cardboard box)
			A	B		
330	stainless steel	5	3.543	7.677	.55	12 pcs. 8.82 lbs. 13x15.7x9.8 in.
331		5	3.543	8.661	.74	12 pcs. 11.24 lbs. 13x15.7x9.8 in.
332		6.7	3.937	8.071	.57	10 pcs. 7.28 lbs. 13x15.7x9.8 in.
333		6.7	3.937	8.858	.77	10 pcs. 9.48 lbs. 13x15.7x9.8 in.

NOTA: Uría se reserva el derecho de hacer cambios en la fabricación de sus artículos sin previo aviso. Asimismo en precios y disponibilidad.

NOTE: Uría reserves the right to make changes in the manufacturing of its products without advanced notice. Prices and availability subject to change.

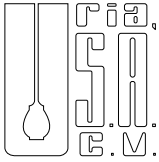

uría, s.a. de c.v.

uria@prodigy.net.mx

55 5272 9066 55 5272 9126 55 5272 9486 55 5273 3576

 55 3189 8670

 @uria.fabrica

 @uria.fabrica

Italianos 16

Col. El Paraíso

01130 Álvaro Obregón, Ciudad de México

MÉXICO

Lunes a viernes de 9:00 a 17:00

Monday to Friday from 9:00 to 17:00

Platos y Tazones





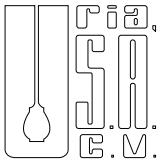

artículos de acero inoxidable
stainless steel products

clave
item no.
184, 185 & 186

- 184 plato para gratinar chico
- 185 plato para gratinar mediano
- 186 plato para gratinar grande

Muy útiles para cualquier gratinado, especialmente de cualquier tipo de enchiladas.

Por su material y grueso calibre, los podrá meter al horno miles de veces. Son verdaderamente eternos, fáciles de limpiar y guardar.

clave	material	peso (kg.)	empaque (caja de cartón)
184	acero inoxidable	.160	24 pzas. 4.10 kg. 230x230x65 mm.
185		.230	24 pzas. 5.70 kg. 230x230x65 mm.
186		.280	24 pzas. 7.30 kg. 230x230x65 mm.

- 184 small au gratin dish
- 185 medium au gratin dish
- 186 large au gratin dish

Useful for any kind of melting; casseroles and enchiladas for example. Their attractive appearance will add elegance to any table presentation.

Because of their heavy gauge stainless steel, they can be used over and over. Easy clean-up and storage.

item no.	material	weight (lbs.)	packaging (cardboard box)
184	stainless steel	.35	24 pcs. 9.04 lbs. 9x9x2.6 in.
185		.51	24 pcs. 12.57 lbs. 9x9x2.6 in.
186		.62	24 pcs. 16.09 lbs. 9x9x2.6 in.

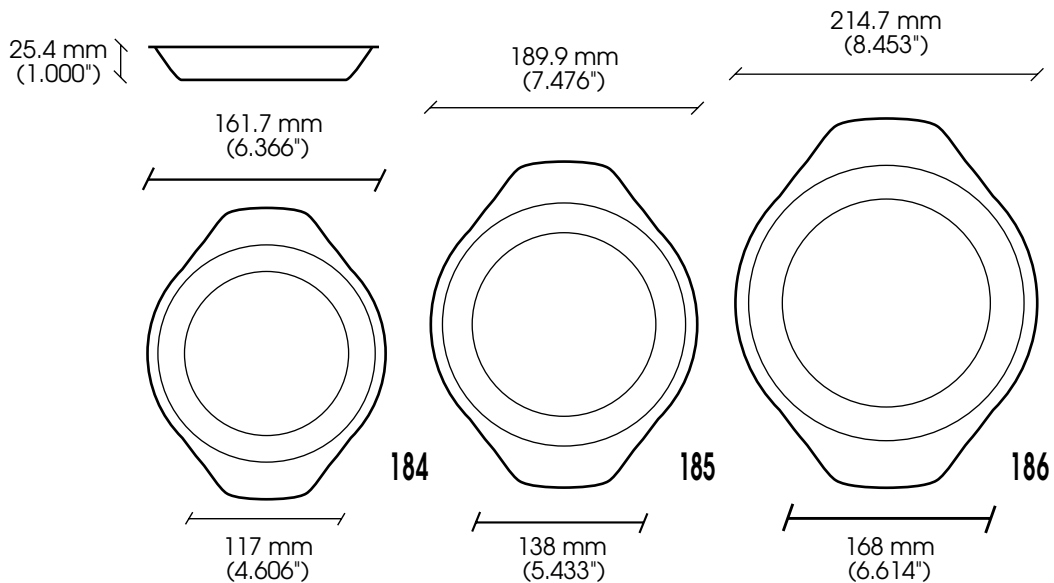

NOTA: Uría se reserva el derecho de hacer cambios en la fabricación de sus artículos sin previo aviso. Asimismo en precios y disponibilidad.

NOTE: Uría reserves the right to make changes in the manufacturing of its products without advanced notice. Prices and availability subject to change.



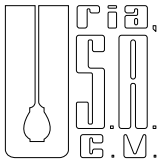

artículos de acero inoxidable
stainless steel products

clave
item no. 187

187 plato base octagonal

Su diseño habla por si mismo.
Preséntelos con vasos octagonales y tendrá el
juego perfecto.
Útil también como charola para bocadillos.

clave	material	peso (kg.)	empaque (caja de cartón)
187	acero inoxidable	.480	24 pzas. 12.10 kg. 300x300x95 mm.

187 octagonal base plate

Its design speaks for itself.
Combine them with eight-sided glasses and
you will have the perfect match.
Also useful as a tray.

item no.	material	weight (lbs.)	packaging (cardboard box)
187	stainless steel	1.06	24 pcs. 26.68 lbs. 11.8x11.8x3.7 in.

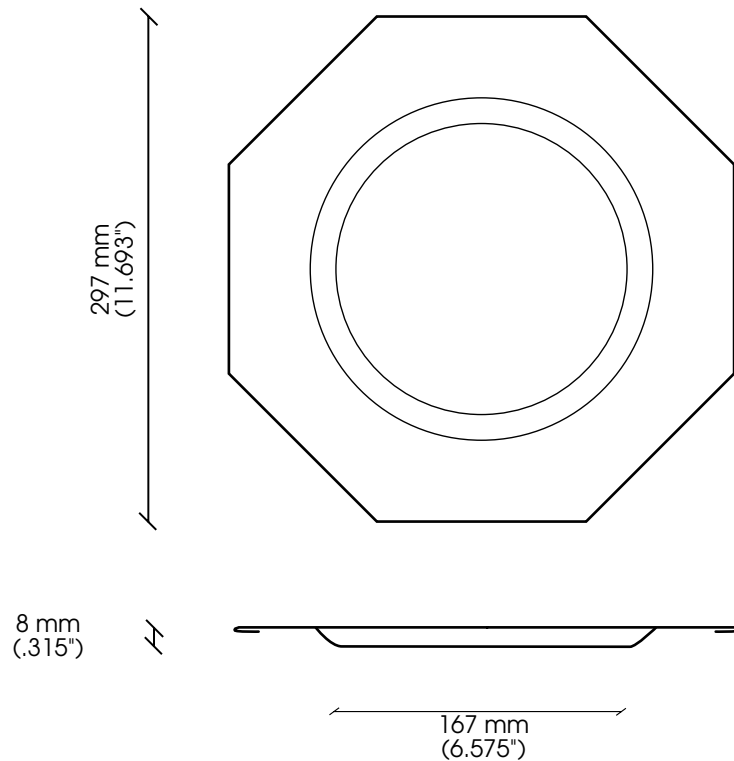

NOTA: Uría se reserva el derecho de hacer cambios en la fabricación de sus artículos sin previo aviso. Asimismo en precios y disponibilidad.

NOTE: Uría reserves the right to make changes in the manufacturing of its products without advanced notice. Prices and availability subject to change.



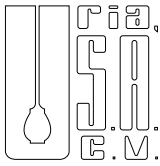

artículos de acero inoxidable
stainless steel products

clave
item no. 202

202 tazón

¿Porqué siempre servir a sus invitados en platos comunes? Use nuestro tazón para sopas, ensaladas, postres, botanas, etc. En la foto le damos ideas para presentar sus maravillosos platillos.

202 table bowl

Why should you always serve your guests in regular plates? Use our table bowl to serve soups, salads, desserts, peanuts, popcorn, etc. We give you some ideas to present your wonderful dishes in the product's photo.

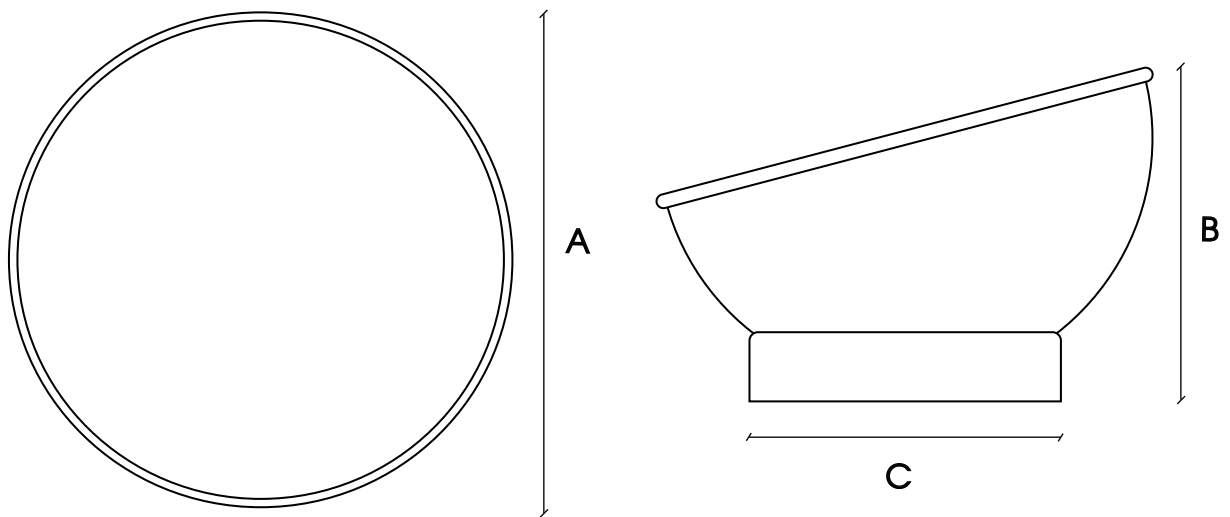

clave	material	capacidad (ml.)	medidas (mm.)			peso (kg.)	empaque (caja de cartón)
			A	B	C		
202	acero inoxidable	450	148	92	90	.210	12 pzas. 2.70 kg. 230x230x225 mm.

item no.	material	capacity (fl. oz.)	dimensions (in.)			weight (lbs.)	packaging (cardboard box)
			A	B	C		
202	stainless steel	15	5.83	3.62	3.54	.46	12 pcs. 5.95 lbs. 9.0x9.0x8.9 in.

NOTA: Uría se reserva el derecho de hacer cambios en la fabricación de sus artículos sin previo aviso. Asimismo en precios y disponibilidad.

NOTE: Uría reserves the right to make changes in the manufacturing of its products without advanced notice. Prices and availability subject to change.

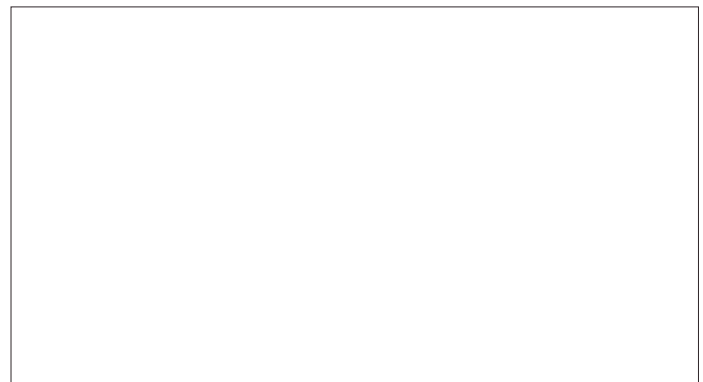

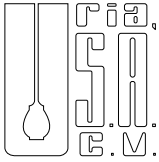

uría, s.a. de c.v.

uria@prodigy.net.mx

55 5272 9066 55 5272 9126 55 5272 9486 55 5273 3576

 55 3189 8670

 @uria.fabrica

 @uria.fabrica

Italianos 16

Col. El Paraíso

01130 Álvaro Obregón, Ciudad de México

MÉXICO

Lunes a viernes de 9:00 a 17:00

Monday to Friday from 9:00 to 17:00

Bar





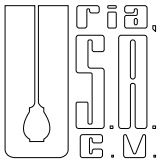

artículos de acero inoxidable
stainless steel products

clave
item no. **352**

352 Jigger

¡Prepara tus bebidas favoritas con nuestro Jigger en forma de Cáliz!
Distinguirá a tu bar con un toque elegante, además de brindarte mayor control de las mismas.
Muy fácil de limpiar.

352 jigger

Prepare your favorite drinks with our unique jigger.
Its Chalice shape will distinguish your bar with an elegant touch and will allow you to keep track of beverages.
Easy to clean and long lasting.

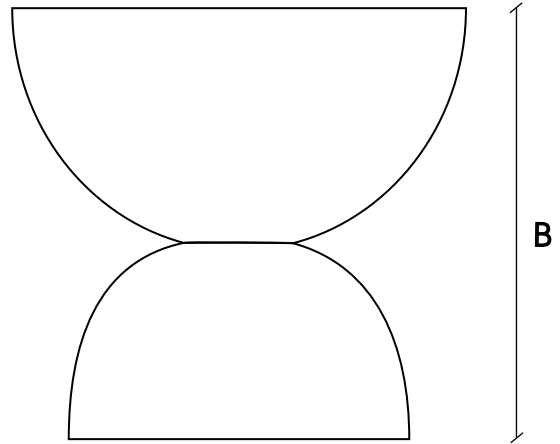
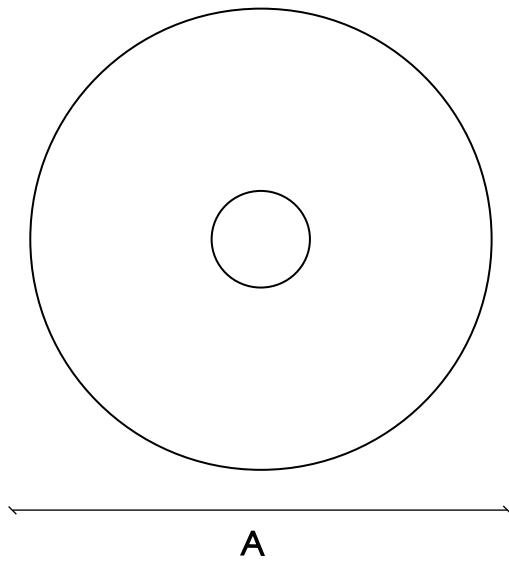

clave	material	capacidad (ml.)	medidas (mm.)		peso (kg.)	empaque (caja de cartón)
			A	B		
352	acero inoxidable	30/60	60	57	.035	12 pzas. .58 kg. 120 x 450 x 95 mm.

item no.	material	capacity (fl. oz.)	dimensions (in.)		weight (lbs.)	packaging (cardboard box)
			A	B		
352	stainless steel	1/2	2.362	2.244	.077	12 pcs. 1.28 lbs. 4.7 x 17.7 x 3.7 in.

NOTA: Uría se reserva el derecho de hacer cambios en la fabricación de sus artículos sin previo aviso. Asimismo en precios y disponibilidad.

NOTE: Uría reserves the right to make changes in the manufacturing of its products without advanced notice. Prices and availability subject to change.

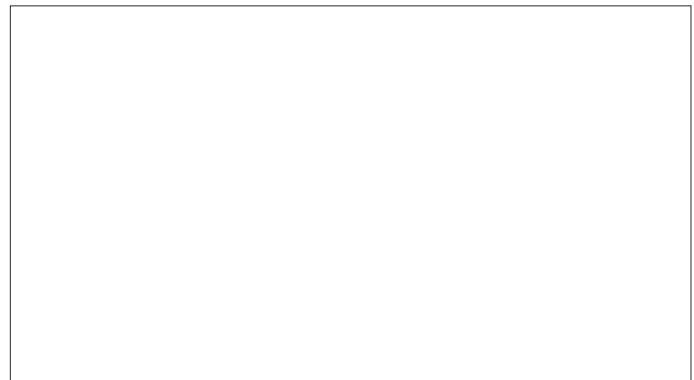

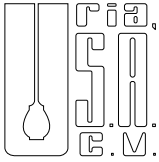

uría, s.a. de c.v.

uria@prodigy.net.mx

55 5272 9066 55 5272 9126 55 5272 9486 55 5273 3576

 55 3189 8670

 @uria.fabrica

 @uria.fabrica

Italianos 16

Col. El Paraíso

01130 Álvaro Obregón, Ciudad de México

MÉXICO

Lunes a viernes de 9:00 a 17:00

Monday to Friday from 9:00 to 17:00

0 1 2 3 4
5 6 7 8 9

Ferretería



0 1 2 3 4
5 6 7 8 9

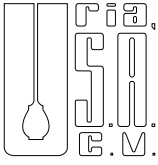

Número Autoadherible

Muy útiles para enumerar departamentos, oficinas, casas, bodegas, etc.
De fácil instalación en interiores y exteriores; simplemente despega y pega sobre diversas superficies. No necesitan mantenimiento.
Se venden individualmente en bolsa de plástico para colgar en rack.

Self-adhesive Number

Very useful for numbering apartments, offices, houses, warehouses, etc.
Indoor or outdoor use. Easy installation on a wide variety of surfaces; simply peel of and paste. Maintenance free.
Individually sold in a plastic bag to hang from a rack.



medidas (mm.)		clave	material	peso (kg.)	presentación individual (bolsa plástico y copete)	empaque (caja de cartón)
A	B					
67	100	0AM, 1AM, 2AM, 3AM, 4AM, 5AM, 6AM, 7AM, 8AM, 9AM	acero inoxidable	.026	.03 kg. 80 x 165 mm.	100 números 3.12 kg. 120 x 450 x 95 mm.

dimensions (in.)		item no.	material	weight (lbs.)	individually bagged (plastic bag & cardboard)	packaging (cardboard box)
A	B					
2.638	3.937	0AM, 1AM, 2AM, 3AM, 4AM, 5AM, 6AM, 7AM, 8AM, 9AM	stainless steel	.057	.07 lbs. 3.1 x 6.5 in.	100 numbers 6.88 lbs. 4.7 x 17.7 x 3.7 in.

NOTA: Uría se reserva el derecho de hacer cambios en la fabricación de sus artículos sin previo aviso. Asimismo en precios y disponibilidad.

NOTE: Uría reserves the right to make changes in the manufacturing of its products without advanced notice. Prices and availability subject to change.

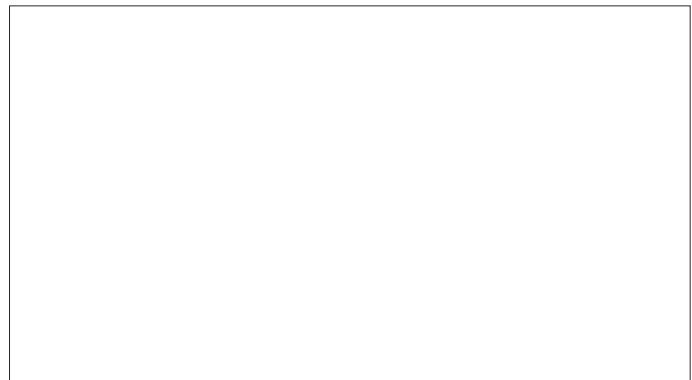

0 1 2 3 4
5 6 7 8 9

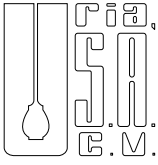

artículos de acero inoxidable
stainless steel products

número autoadherible negro

Número Autoadherible Negro

Muy útiles para enumerar departamentos, oficinas, casas, bodegas, etc.
De fácil instalación en interiores y exteriores; simplemente despega y pega sobre diversas superficies. Muy fáciles de limpiar.
Se venden individualmente en bolsa de plástico para colgar en rack.

Black Self-adhesive Number

Very useful for numbering apartments, offices, houses, warehouses, etc.
Indoor or outdoor use. Easy installation on a wide variety of surfaces; simply peel off and paste. Easy maintenance.
Individually sold in a plastic bag to hang from a rack.



medidas (mm.)		clave	material	peso (kg.)	presentación individual (bolsa plástico y copete)	empaque (caja de cartón)
A	B					
67	100	0AMN, 1AMN, 2AMN, 3AMN 4AMN, 5AMN, 6AMN, 7AMN 8AMN, 9AMN	acero inoxidable pintado mate	.026	.03 kg. 80 x 165 mm.	100 números 3.12 kg. 120 x 450 x 95 mm.

dimensions (in.)		item no.	material	weight (lbs.)	individually bagged (plastic bag & cardboard)	packaging (cardboard box)
A	B					
2.638	3.937	0AMN, 1AMN, 2AMN, 3AMN 4AMN, 5AMN, 6AMN, 7AMN 8AMN, 9AMN	stainless steel matt painted	.057	.07 lbs. 3.1 x 6.5 in.	100 numbers 6.88 lbs. 4.7 x 17.7 x 3.7 in.

NOTA: Uría se reserva el derecho de hacer cambios en la fabricación de sus artículos sin previo aviso. Asimismo en precios y disponibilidad.

NOTE: Uría reserves the right to make changes in the manufacturing of its products without advanced notice. Prices and availability subject to change.

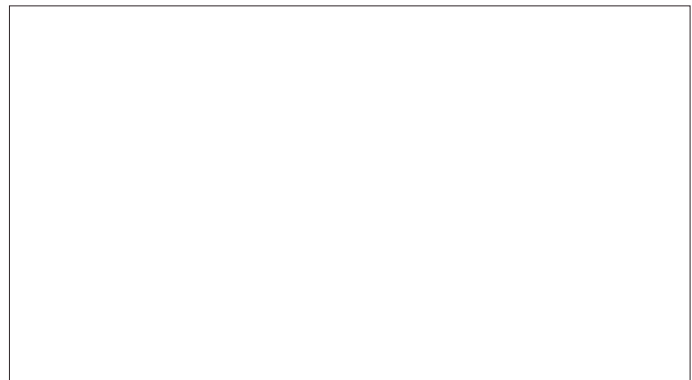

a



B



C



D



E



F



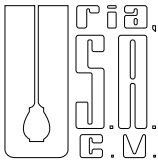

Letra Autoadherible

Fabricamos las letras más utilizadas en los ámbitos residencial y comercial para identificar departamentos, casas, oficinas, hospitales, locales de malls, columnas de estacionamientos... ¡COMBÍNELAS CON NUESTROS NÚMEROS!

De fácil instalación en interiores y exteriores; simplemente despega y pega sobre diversas superficies. No necesitan mantenimiento.

Se venden individualmente en bolsa de plástico para colgar en rack.

Self-adhesive Letter

We manufacture the most common letters for residential and commercial use. Identify apartments, homes, offices, hospitals, malls, parking lots columns... USE THEM WITH OUR NUMBERS!

Indoor or outdoor use. Easy installation on a wide variety of surfaces; simply peel off and paste. Maintenance free.

Individually sold in a plastic bag to hang from a rack.



medidas (mm.)		clave	material	peso (kg.)	presentación individual (bolsa plástico y copete)	empaque (caja de cartón)
A	B					
67	100	AAM, BAM, CAM, DAM, EAM, FAM	acero inoxidable	.026	.03 kg. 80 x 165 mm.	100 letras 3.12 kg. 120 x 450 x 95 mm.

dimensions (in.)		item no.	material	weight (lbs.)	individually bagged (plastic bag & cardboard)	packaging (cardboard box)
A	B					
2.638	3.937	AAM, BAM, CAM, DAM, EAM, FAM	stainless steel	.057	.07 lbs. 3.1 x 6.5 in.	100 letters 6.88 lbs. 4.7 x 17.7 x 3.7 in.

NOTA: Uría se reserva el derecho de hacer cambios en la fabricación de sus artículos sin previo aviso. Asimismo en precios y disponibilidad.

NOTE: Uría reserves the right to make changes in the manufacturing of its products without advanced notice. Prices and availability subject to change.



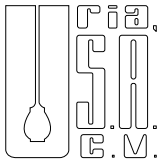

Letra Autoadherible Negra

Nuestras letras también en negro, muy útiles para identificar departamentos, casas, oficinas, hospitales, locales de malls, columnas de estacionamientos...
¡COMBÍNELAS CON NUESTROS NÚMEROS NEGROS!

De fácil instalación en interiores y exteriores; simplemente despegas y pega sobre diversas superficies. Muy fáciles de limpiar.

Se venden individualmente en bolsa de plástico para colgar en rack.

Black Self-adhesive Letter

Our letters also in black, very usefull for identifying apartments, houses, offices, hospitals, malls, parking lots columns... USE THEM WITH OUR BLACK NUMBERS!

Indoor or outdoor use. Easy installation on a wide variety of surfaces; simply peel off and paste. Easy maintenance.

Individually sold in a plastic bag to hang from a rack.



medidas (mm.)		clave	material	peso (kg.)	presentación individual (bolsa plástico y copete)	empaque (caja de cartón)
A	B					
67	100	AAMN, BAMN, CAMN, DAMN, EAMN, FAMN	acero inoxidable pintado mate	.026	.03 kg. 80 x 165 mm.	100 letras 3.12 kg. 120 x 450 x 95 mm.

dimensions (in.)		item no.	material	weight (lbs.)	individually bagged (plastic bag & cardboard)	packaging (cardboard box)
A	B					
2.638	3.937	AAMN, BAMN, CAMN, DAMN, EAMN, FAMN	stainless steel matt painted	.057	.07 lbs. 3.1 x 6.5 in.	100 letters 6.88 lbs. 4.7 x 17.7 x 3.7 in.

NOTA: Uría se reserva el derecho de hacer cambios en la fabricación de sus artículos sin previo aviso. Asimismo en precios y disponibilidad.

NOTE: Uría reserves the right to make changes in the manufacturing of its products without advanced notice. Prices and availability subject to change.

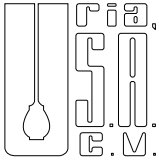

uría, s.a. de c.v.

uria@prodigy.net.mx

55 5272 9066 55 5272 9126 55 5272 9486 55 5273 3576

 55 3189 8670

 @uria.fabrica

 @uria.fabrica

Italianos 16

Col. El Paraíso

01130 Álvaro Obregón, Ciudad de México

MÉXICO

Lunes a viernes de 9:00 a 17:00

Monday to Friday from 9:00 to 17:00

**Le ponemos la sal
a su vida...**

